

RANCO srl

- Normalizzati per stampi -



Staffe

Clamps

Staffe - Indice

Clamps - Index

S210 - Staffe semplici (DIN 6314) S210 - Standard clamps (DIN6314)	pag.: 03
S211 - Staffe semplici ridotte S211 - Shaped standard clamps	pag.: 03
S220 - Staffe dentate (DIN 6314Z) S220 - Toothed clamps (DIN6314Z)	pag.: 04
S230 - Staffe regolabili con vite passo fine (DIN 6314V) S230 - Adjustable clamps with fine pitch screw (DIN 6314V)	pag.: 04
S280 - Staffe regolabili con vite passo quadro S280 - Adjustable clamps with square thread screw	pag.: 05
S281 - Viti di ricambio per staffe S281 - Spare screw for clamps	pag.: 05
S310 - Viti testa a martello complete di dado S340 e rondella S370 S310 - Hammerhead bolts complete with nut S340 and washer S370	pag.: 06
S311 - Viti testa a martello singole S311 - Single hammerhead bolts	pag.: 07
S315 - Viti testa a martello complete di dado S340 e rondella S390 S315 - Hammerhead bolts complete with nut S340 and washer S390	pag.: 08
S316 - Viti testa a martello singole S316 - Single hammerhead bolts	pag.: 09
S320 - Prigionieri completi di dado S330 e rondella S370 S320 - Studs complete with short nut S330 and washer S370	pag.: 10
S321 - Prigionieri singoli S321 - Single studs	pag.: 11
S330 - Dadi bassi torniti S330 - Turned short nuts	pag.: 12
S340 - Dadi alti torniti S340 - Turned tall nuts	pag.: 12
S350 - Dadi prolungamento S350 - Extension nuts	pag.: 13
S351 - Dadi con rondella S351 - Nuts with washer	pag.: 13
S360 - Tasselli per cave a "T" S360 - Nuts for "T" slot	pag.: 14
S361 - Tasselli per cave a "T" senza foro S361 - Blanks T-Nuts	pag.: 14
S362 - Tasselli per cave a "T" doppia lunghezza S362 - Extended nuts for T-slot	pag.: 15
S363 - Tasselli per cave romboidali S363 - Nuts for T-slot "Rhombus"	pag.: 15
S370; S380; S390 - Rondelle tornite S370; S380; S390 - Washers	pag.: 16

S210

- Staffa semplice (DIN 6314)

- Standard clamp (DIN 6314)

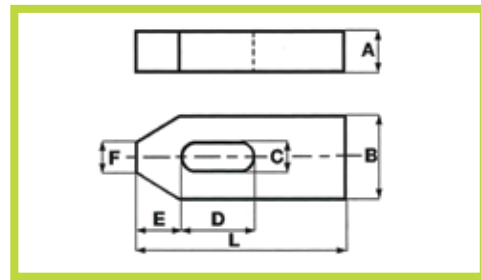

Materiale: Acciaio da bonifica verniciato R.>700 N/mm²

Material: Hardened painted steel R.>700 N/mm²

Esempio di ordinativo : Codice
Example of purchasing order : Code

Codice/Code	A	B	L	C	D	E	F		gr
S210.07050	10	20	50	7	20	10	8	6	65
S210.09060	12	25	60	9	22	13	10	8	115
S210.11080	15	30	80	11	30	15	12	10	225
S210.14100	20	40	100	14	40	21	14	12 - 14	500
S210.14125	20	40	125	14	50	21	14	12 - 14	620
S210.14160	20	40	160	14	65	21	14	12 - 14	815
S210.18125	25	50	125	18	45	26	18	16 - 18	980
S210.18160	25	50	160	18	65	26	18	16 - 18	1260
S210.18200	25	50	200	18	80	26	18	16 - 18	1600
S210.22160	30	60	160	22	60	30	22	20 - 22	1850
S210.22200	30	60	200	22	80	30	22	20 - 22	2300
S210.26200	30	70	200	26	80	35	26	24	2650
S210.26250	30	70	250	26	105	35	26	24	3300
S210.34250	40	80	250	34	100	45	34	27 - 30	5000
S210.34315	40	80	315	34	130	45	34	27 - 30	6200

S211

- Staffa semplice ridotta

- Shaped standard clamp

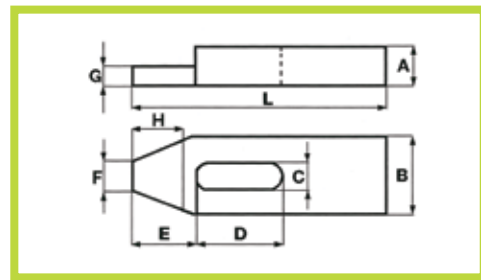

Materiale: Acciaio da bonifica verniciato R.>700 N/mm²

Material: Hardened painted steel R.>700 N/mm²

Esempio di ordinativo : Codice
Example of purchasing order : Code

Codice/Code	G	A	B	L	C	D	E	F	H		gr
S211.07050	6	10	20	50	7	20	10	8	7	6	60
S211.09060	7	12	25	60	9	22	13	10	10	8	140
S211.11080	9	15	30	80	11	30	15	12	9	10	220
S211.14100	12	20	40	100	14	40	21	12	12	12 - 14	480
S211.14125	12	20	40	125	14	50	21	14	12	12 - 14	615
S211.14160	12	20	40	160	14	65	26	14	12	12 - 14	800
S211.18125	15	25	50	125	18	45	26	18	15	16 - 18	960
S211.18160	15	25	50	160	18	65	26	18	15	16 - 18	1230
S211.18200	15	25	50	200	18	80	26	18	15	16 - 18	1550
S211.22160	20	30	60	160	22	60	30	22	20	20 - 22	1800
S211.22200	20	30	60	200	22	80	30	22	20	20 - 22	2200
S211.26200	20	30	70	200	26	80	35	26	25	24	2450
S211.26250	20	30	70	250	26	105	35	26	25	24	3200
S211.34250	25	40	80	250	34	100	45	34	25	27 - 30	4800
S211.34315	25	40	80	315	34	130	45	34	25	27 - 30	6000

S220

- Staffa dentata (DIN 6314Z)
- Toothed clamp (DIN 6314Z)

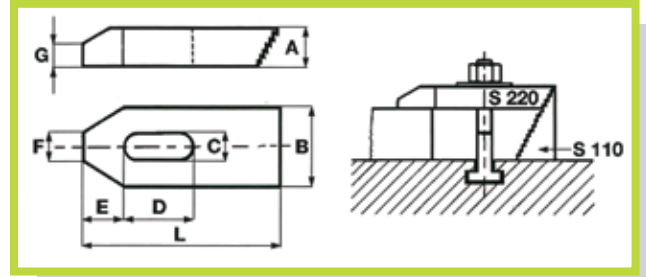

Materiale: Acciaio da bonifica verniciato R.>700 N/mm²
Material: Hardened painted steel R.>700 N/mm²

Esempio di ordinativo : Codice
Example of purchasing order : Code

Codice/Code	A	B	L	C	D	E	F	G		gr
S220.07050	10	20	50	7	20	10	8	6	6	55
S220.09060	12	25	60	9	22	13	10	8	8	125
S220.11080	15	30	80	11	30	15	12	10	10	205
S220.14100	20	40	100	14	40	21	14	12	12 - 14	445
S220.18125	25	50	125	18	45	26	18	15	16 - 18	930
S220.22160	30	60	160	22	60	30	22	18	20 - 22	1700
S220.26200	30	70	200	26	80	35	26	18	24	2500

S230

- Staffa regolabile con vite passo fine (DIN 6314V)
- Adjustable clamp with fine pitch screw (DIN 6314V)

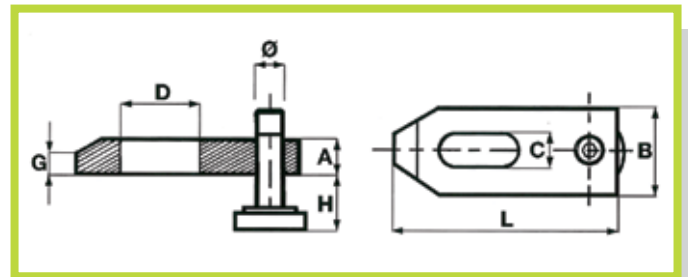

Materiale: Acciaio da bonifica verniciato R.>700 N/mm²
Material: Hardened painted steel R.>700 N/mm²

Esempio di ordinativo : Codice
Example of purchasing order : Code

Codice/Code	A	B	L	H	C	D	Ø	G		gr
S230.11080	15	30	80	8 - 28	11	30	M10	10	10	215
S230.14100	20	40	100	10 - 32	14	40	M12	12	12 - 14	470
S230.18125	25	50	125	13 - 40	18	45	M16	15	16 - 18	940
S230.22160	30	60	160	18 - 60	22	60	M20	18	20 - 22	1730

Viti Ricambio - Spare Screws

Codice/Code	A	B	L	H	gr
S231.00010	40	M10	60	8	130
S231.00012	45	M12	60	8	210
S231.00016	45	M16	70	8	245
S231.00020	45	M20	80	8	300

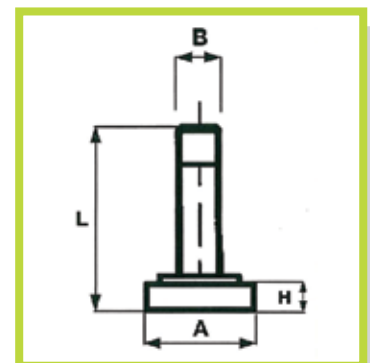

S280

- Staffa regolabile con vite passo quadro
- Adjustable clamp with square thread screw

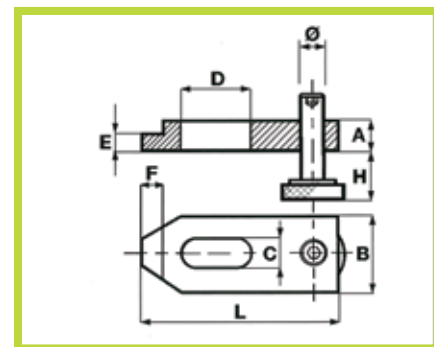

Materiale: Acciaio da bonifica verniciato R.>700 N/mm²
Material: Hardened painted steel R.>700 N/mm²

Esempio di ordinativo : Codice
Example of purchasing order : Code

Codice/Code	A	B	L	H	C	D	Ø	E	F		gr
S280.14100	20	40	100	15 - 50	15	40	20x4	12	12	12 - 14	430
S280.14125	20	40	125	15 - 50	15	45	20x4	12	12	12 - 14	580
S280.14160	20	40	160	15 - 50	15	60	20x4	12	12	12 - 14	760
S280.18125	25	50	125	15 - 70	19	45	20x4	15	15	16 - 18	900
S280.18160	25	50	160	15 - 70	19	60	30x6	15	15	16 - 18	1100
S280.18200	25	50	200	15 - 70	19	80	30x6	15	15	16 - 18	1430
S280.22160	30	60	160	15 - 70	23	60	30x6	15	20	20 - 22	1580
S280.22200	30	60	200	15 - 70	23	80	30x6	15	20	20 - 22	2030
S280.26200	40	70	200	15 - 70	27	80	30x6	25	23	24	3160
S280.26250	40	70	250	15 - 70	27	100	30x6	25	23	24	4080
S280.26300	40	70	300	15 - 70	27	100	30x6	25	23	24	5200

S281

- Vite di ricambio per staffe
- Spare screw for clamps

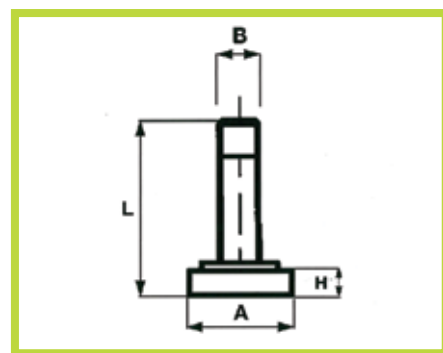

Materiale: 35 SMn Pb 10 UNI 4838 Classe 8.8
Material: 35 SMn Pb 10 UNI 4838 Class 8.8

Esempio di ordinativo : Codice
Example of purchasing order : Code

Codice/Code	A	B	L	H	gr
S281.20004	35	20x4	70	10	190
S281.30006	40	30x6	100	15	540

S310

- Vite testa a martello completa di dado S340 e rondella S370 (DIN 787)
 - Hammerhead bolt complete with nut S340 and washer S370 (DIN 787)

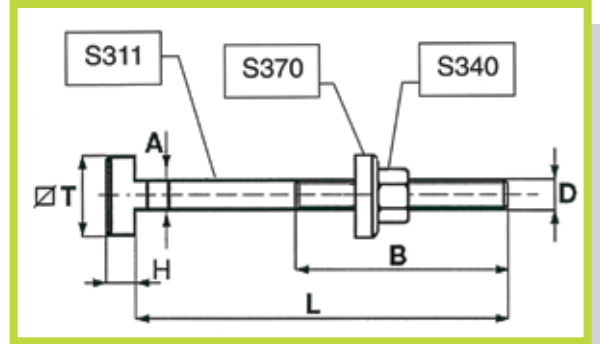

Materiale: UNI 42 CrMo4 a norma ASTM A 193-B7 Classe 10.9.
 Material: UNI 42 CrMo4 According to standard ASTM A 193-B7 Class 10.9.

Esempio di ordinativo : Codice
 Example of purchasing order : Code

Codice/Code	D	L	B	A	T	H	Cava	gr	Codice/Code	D	L	B	A	T	H	Cava	gr
S310.10040	M10	40	30	9,7	15	6	10	60	S310.18080	M18	80	55	17,7	28	10	18	315
S310.10060		63	45					80	S310.18100		100	65					335
S310.10080		80	55					85	S310.18125		125	85					410
S310.10100		100	60					100	S310.18150		150	100					450
S310.10125		125	75					105	S310.18170		170	100					480
S310.10150		150	100					120	S310.18200		200	125					530
S310.10170		170	100					130	S310.18230		230	150					560
S310.12050	M12	50	35	11,7	18	7	12	110	S310.20080	M20	80	55	19,7	32	12	20	440
S310.12060		63	45					115	S310.20100		100	63					490
S310.12080		80	55					125	S310.20125		125	85					540
S310.12100		100	60					140	S310.20150		150	100					600
S310.12125		125	75					150	S310.20160		160	110					620
S310.12150		150	100					180	S310.20170		170	100					625
S310.12170		170	100					195	S310.20200		200	125					700
S310.12200	200	120	210	S310.20230	230	150	820										
S310.14060	M14	63	40	13,7	22	8	14	160	S310.20315	M22	315	190	21,7	35	14	22	950
S310.14080		80	55					180	S310.22080		80	55					540
S310.14100		100	65					215	S310.22100		100	63					580
S310.14125		125	75					240	S310.22125		125	85					630
S310.14150		150	100					270	S310.22150		150	100					710
S310.14170		170	100					290	S310.22170		170	100					790
S310.14200		200	125					260	S310.22200		200	125					870
S310.14230	230	150	345	S310.22230	230	150	890										
S310.16060	M16	63	45	15,7	25	9	16	230	S310.24080	M24	80	55	23,7	40	16	24	720
S310.16080		80	55					250	S310.24100		100	70					810
S310.16100		100	63					270	S310.24125		125	85					870
S310.16125		125	75					315	S310.24150		150	100					980
S310.16150		150	100					345	S310.24160		160	110					1010
S310.16160		160	100					360	S310.24170		170	100					1040
S310.16170		170	100					370	S310.24200		200	125					1170
S310.16200	200	125	405	S310.24230	230	150	1220										
S310.16230	230	150	450	S310.24250	250	150	1230										
S310.16250	250	150	470														

S311

- Vite testa a martello singola (DIN 787)
- Single hammerhead bolt (DIN 787)

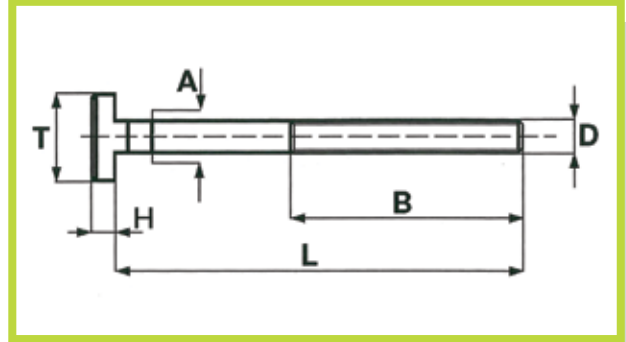

Materiale: UNI 42 CrMo4 a norma ASTM A 193-B7 Classe 10.9.
Material: UNI 42 CrMo4 According to standard ASTM A 193-B7 Class 10.9.

Esempio di ordinativo : Codice
Example of purchasing order : Code

Codice/Code	D	L	B	A	T	H	Cava	gr	Codice/Code	D	L	B	A	T	H	Cava	gr
S311.10040	M10	40	30	9,7	15	6	10	30	S311.18080	M18	80	55	17,7	28	10	18	185
S311.10060		63	45					50	S311.18100		100	65					203
S311.10080		80	55					55	S311.18125		125	85					280
S311.10100		100	60					70	S311.18150		150	100					320
S311.10125		125	75					75	S311.18170		170	100					350
S311.10150		150	100					90	S311.18200		200	125					400
S311.10170		170	100					100	S311.18230		230	150					430
S311.12050	M12	50	35	11,7	18	7	12	60	S311.20080	M20	80	55	19,7	32	12	20	290
S311.12060		63	45					65	S311.20100		100	63					340
S311.12080		80	55					75	S311.20125		125	85					390
S311.12100		100	60					90	S311.20150		150	100					450
S311.12125		125	75					110	S311.20160		160	110					470
S311.12150		150	100					130	S311.20170		170	100					475
S311.12170		170	100					145	S311.20200		200	125					550
S311.12200	200	120	160	S311.20230	230	150	670										
S311.14060	M14	63	40	13,7	22	8	14	80	S311.20315	M22	315	190	21,7	35	14	22	800
S311.14080		80	55					100	S311.22080		80	55					330
S311.14100		100	65					135	S311.22100		100	63					370
S311.14125		125	75					160	S311.22125		125	85					430
S311.14150		150	100					190	S311.22150		150	100					500
S311.14170		170	100					210	S311.22170		170	100					590
S311.14200		200	125					235	S311.22200		200	125					660
S311.14230	230	150	265	S311.22230	230	150	680										
S311.16060	M16	63	45	15,7	25	9	16	140	S311.24080	M24	80	55	23,7	40	16	24	450
S311.16080		80	55					160	S311.24100		100	70					550
S311.16100		100	63					180	S311.24125		125	85					600
S311.16125		125	75					225	S311.24150		150	100					710
S311.16150		150	100					255	S311.24160		160	110					740
S311.16160		160	100					270	S311.24170		170	100					770
S311.16170		170	100					280	S311.24200		200	125					900
S311.16200	200	125	315	S311.24230	230	150	950										
S311.16230	230	150	360	S311.24250	250	150	960										
S311.16250	250	150	380														

S315

- Vite testa a martello completa di dado S340 e rondella S390 (DIN 787)

- Hammerhead bolt complete with nut S340 and washer S390 (DIN 787)

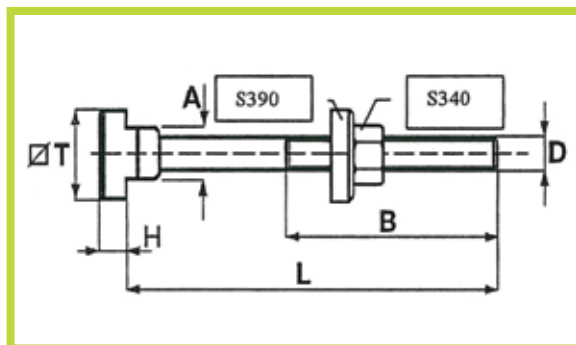

Materiale: UNI 42 CrMo4 a norma ASTM A 193-B7 Classe 10.9.

Material: UNI 42 CrMo4 According to standard ASTM A 193-B7 Class 10.9.

Esempio di ordinativo : Codice
Example of purchasing order : Code

Codice/Code	D	L	B	A	T	H	Cava	gr
S315.12050	M12	50	35	13,7	22	8	14	145
S315.12063		63	45					150
S315.12080		80	55					165
S315.12125		125	75					185
S315.12200		200	120					245
S315.14063	M14	63	45	15,7	25	9	16	210
S315.14100		100	63					245
S315.14160		160	100					305
S315.14230		230	150					370
S315.16063	M16	63	45	17,7	28	10	18	290
S315.16080		80	55					315
S315.16100		100	63					335
S315.16125		125	85					380
S315.16160		160	100					410
S315.16200		200	125					475
S315.16230		230	150					520
S315.16250		250	150					560
S315.20080		M20	80					55
S315.20100	100		63	565				
S315.20125	125		85	615				
S315.20160	160		110	675				
S315.20200	200		125	755				
S315.20230	230		150	830				
S315.20315	315		190	1010				
S315.24100	M24	100	70	27,7	44	18	28	1020
S315.24125		125	85					1110
S315.24160		160	110					1170
S315.24200		200	125					1320
S315.24230		230	150					1430
S315.24250		250	150					1490
S315.24315		315	240					1860

S316

- Vite testa a martello singola (DIN 787)

- Single hammerhead bolt (DIN 787)

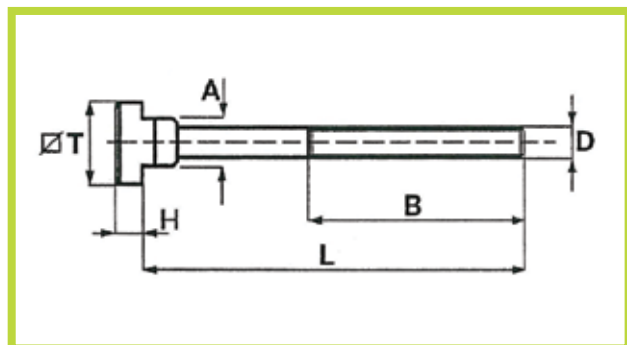

Materiale: UNI 42 CrMo4 a norma ASTM A 193-B7 Classe 10.9.

Material: UNI 42 CrMo4 According to standard ASTM A 193-B7 Class 10.9.

Esempio di ordinativo : Codice
Example of purchasing order : Code

Codice/Code	D	L	B	A	T	H	Cava	gr
S316.12050	M12	50	35	13,7	22	8	14	80
S316.12063		63	45					85
S316.12080		80	55					100
S316.12125		125	75					120
S316.12200		200	120					180
S316.14063	M14	63	45	15,7	25	9	16	125
S316.14100		100	63					160
S316.14160		160	100					220
S316.14230		230	150					285
S316.16063	M16	63	45	17,7	28	10	18	160
S316.16080		80	55					185
S316.16100		100	63					205
S316.16125		125	85					250
S316.16160		160	100					280
S316.16200		200	125					345
S316.16230		230	150					390
S316.16250		250	150					430
S316.20080	M20	80	55	21,7	35	14	22	330
S316.20100		100	63					380
S316.20125		125	85					430
S316.20160		160	110					490
S316.20200		200	125					570
S316.20230		230	150					645
S316.20315		315	190					820
S316.24100	M24	100	70	27,7	44	18	28	650
S316.24125		125	85					740
S316.24160		160	110					800
S316.24200		200	125					950
S316.24230		230	150					1060
S316.24250		250	150					1120
S316.24315		315	240					1490

S320

- Prigioniere completo di dado S330 e rondella S370 (DIN 6379)

- Stud complete with short nut S330 and washer S370 (DIN 6379)

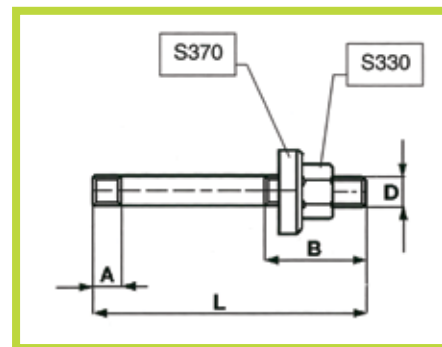

Materiale: UNI 42 CrMo4 a norma
ASTM A 193-B7 Classe 10.9. filetto ottenuto per rullatura

Material: UNI 42 CrMo4 According to standard
ASTM A 193-B7 Class 10.9. rolled thread

Esempio di ordinativo : Codice
Example of purchasing order : Code

Codice/Code	D	L	A	B	gr	Codice/Code	D	L	A	B	gr	Codice/Code	D	L	A	B	gr
S320.08040		40		20	25	S320.16065		63		35	160	S320.24100		100		45	490
S320.08060		63		40	35	S320.16080		80		50	180	S320.24125		125		70	580
S320.08080		80		50	40	S320.16100		100		63	205	S320.24160		160		100	670
S320.08100	M8	100	11	63	45	S320.16125		125		75	235	S320.24200	M24	200	35	125	780
S320.08125		125		75	50	S320.16160	M16	160	19	100	295	S320.24225		225		125	870
S320.08160		160		100	60	S320.16200		200		125	355	S320.24250		250		160	930
S320.08200		200		100	80	S320.16225		225		160	370	S320.24315		315		180	1120
S320.10050		50		25	50	S320.16250		250		160	400	S320.27125		125		56	785
S320.10060		60		35	55	S320.16315		315		180	500	S320.27150		150		80	870
S320.10080		80		50	65	S320.18080		80		50	230	S320.27200		200		125	1070
S320.10100	M10	100	13	75	75	S320.18100		100		50	265	S320.27225	M27	225	39	160	1160
S320.10120		120		75	85	S320.18125		125		75	300	S320.27250		250		160	1260
S320.10160		160		100	105	S320.18160	M18	160	23	100	355	S320.27315		315		200	1410
S320.10200		200		125	125	S320.18200		200		125	420	S320.27400		400		250	1835
S320.12050		50		25	80	S320.18225		225		150	465	S320.27500		500		315	2230
S320.12060		63		32	85	S320.18250		250		150	500	S320.30125		125		56	960
S320.12080		80		50	95	S320.18315		315		150	600	S320.30150		150		80	1080
S320.12100		100		63	110	S320.20080		80		30	305	S320.30200		200		125	1320
S320.12125	M12	125	15	75	130	S320.20125		125		70	375	S320.30250	M30	250	43	160	1550
S320.12160		160		100	155	S320.20160		160		100	450	S320.30315		315		200	1860
S320.12200		200		125	180	S320.20200	M20	200	27	125	530	S320.30400		400		250	2250
S320.12225		225		160	205	S320.20225		225		160	585	S320.30500		500		315	2730
S320.12250		250		160	220	S320.20250		250		160	630	S320.30700		700		400	3670
S320.14060		63		32	145	S320.20315		315		32	760	S320.36160		160		80	1725
S320.14080		80		50	150	S320.22100		100		45	440	S320.36200		200		125	1965
S320.14100		100		63	160	S320.22120		120		63	470	S320.36250		250		160	2335
S320.14120	M14	120	17	75	185	S320.22160		160		100	600	S320.36315	M36	315	51	200	2775
S320.14160		160		100	215	S320.22200	M22	200	31	125	670	S320.36400		400		250	3365
S320.14200		200		125	260	S320.22225		225		160	740	S320.36500		500		315	4165
S320.14225		225		160	290	S320.22250		250		160	840	S320.36700		700		400	5405
S320.14250		250		160	305	S320.22315		315		250	920						

S321

- Prigioniere singolo (DIN 6379)

- Single stud (DIN 6379)

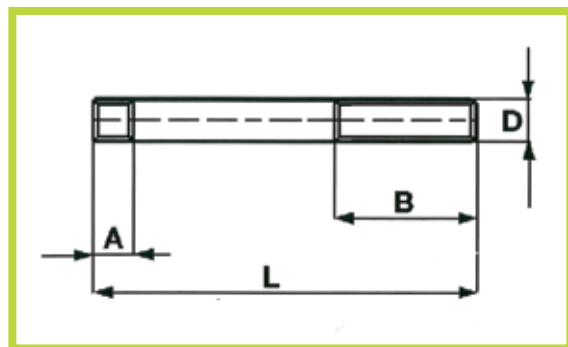

Materiale: UNI 42 CrMo4 a norma
ASTM A 193-B7 Classe 10.9. filetto ottenuto per rullatura

Material: UNI 42 CrMo4 According to standard
ASTM A 193-B7 Class 10.9. rolled thread

Esempio di ordinativo : Codice
Example of purchasing order : Code

Codice/Code	D	L	A	B	gr	Codice/Code	D	L	A	B	gr	Codice/Code	D	L	A	B	gr
S321.08040	M8	40	11	20	13	S321.16065	M16	63	19	35	85	S321.24100	M24	100	35	45	290
S321.08060		63		40	20	S321.16080		80		50	105	S321.24125		125		70	380
S321.08080		80		50	25	S321.16100		100		63	130	S321.24160		160		100	470
S321.08100		100		63	30	S321.16125		125		75	160	S321.24200		200		125	580
S321.08125		125		75	36	S321.16160		160		100	220	S321.24225		225		125	670
S321.08160		160		100	45	S321.16200		200		125	280	S321.24250		250		160	730
S321.08200		200		100	65	S321.16225		225		160	295	S321.24315		315		180	920
S321.10050	M10	50	13	25	25	S321.16250	M18	250	23	160	325	S321.27125	M27	125	39	56	485
S321.10060		60		35	30	S321.16315		315		180	425	S321.27150		150		80	570
S321.10080		80		50	40	S321.18080		80		50	130	S321.27200		200		125	770
S321.10100		100		75	50	S321.18100		100		50	165	S321.27225		225		160	860
S321.10120		120		75	65	S321.18125		125		75	200	S321.27250		250		160	960
S321.10160		160		100	80	S321.18160		160		100	255	S321.27315		315		200	1110
S321.10200		200		125	100	S321.18200		200		125	320	S321.27400		400		250	1535
S321.12050	M12	50	15	25	37	S321.18225	M20	225	27	150	365	S321.27500	M30	500	43	315	1930
S321.12060		63		32	45	S321.18250		250		150	400	S321.30125		125		56	590
S321.12080		80		50	55	S321.18315		315		180	500	S321.30150		150		80	710
S321.12100		100		63	70	S321.20080		80		32	185	S321.30200		200		125	950
S321.12125		125		75	90	S321.20125		125		70	255	S321.30250		250		160	1180
S321.12160		160		100	115	S321.20160		160		100	330	S321.30315		315		200	1490
S321.12200		200		125	140	S321.20200		200		125	410	S321.30400		400		250	1880
S321.12225	225	160	165	S321.20225	225	160	465	S321.30500	500	315	2360						
S321.12250	250	160	180	S321.20250	250	160	510	S321.30700	700	400	3300						
S321.14060	M14	63	17	32	80	S321.20315	M22	315	31	200	640	S321.36160	M36	160	51	80	1100
S321.14080		80		50	80	S321.22100		100		45	270	S321.36200		200		125	1340
S321.14100		100		63	95	S321.22120		120		63	300	S321.36250		250		160	1710
S321.14120		120		75	120	S321.22160		160		100	430	S321.36315		315		200	2150
S321.14160		160		100	150	S321.22200		200		125	500	S321.36400		400		250	2740
S321.14200		200		125	195	S321.22225		225		160	570	S321.36500		500		315	3540
S321.14225		225		160	225	S321.22250		250		160	670	S321.36700		700		400	4780
S321.14250	250	160	240	S321.22315	315	250	750										

S330

- Dado basso tornito (UNI 5587)
- Turned short nut (UNI 5587)



Materiale: Acciaio classe 10K.
Material: Steel class 10K.

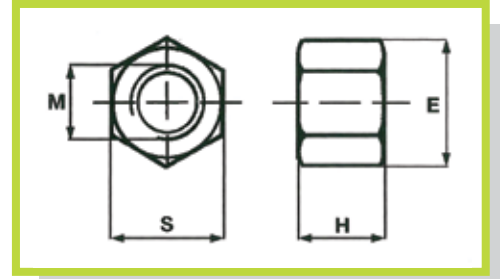

Esempio di ordinativo : Codice
Example of purchasing order : Code

Codice/Code	M	S	E	H	gr
S330.08008	8	13	14,8	8	6
S330.10010	10	17	19,6	10	15
S330.12012	12	19	21,5	12	20
S330.14014	14	22	25	14	30
S330.16016	16	24	27,5	16	40
S330.18018	18	27	31	18	60
S330.20020	20	30	34,6	20	80
S330.22022	22	32	36,9	22	95
S330.24024	24	36	41,6	24	135
S330.27027	27	41	47,3	27	195
S330.30030	30	46	53,1	30	275
S330.36036	36	55	63,5	36	465
S330.42042	42	65	75	42	790
S330.48048	48	75	86,5	48	1200

S340

- Dado alto tornito (DIN 6330B)
- Turned tall nut (DIN 6330B)



Materiale: Acciaio classe 10K.
Material: Steel class 10K.

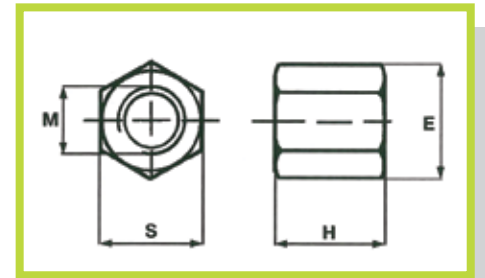

Esempio di ordinativo : Codice
Example of purchasing order : Code

Codice/Code	M	S	E	H	gr
S340.06009	6	10	11,5	9	5
S340.08012	8	13	14,8	12	9
S340.10015	10	17	19,6	15	20
S340.12018	12	19	21,5	18	28
S340.14021	14	22	25	21	45
S340.16024	16	24	27,5	24	58
S340.18027	18	27	31	27	83
S340.20030	20	30	34,6	30	110
S340.22033	22	32	36,9	33	130
S340.24036	24	36	41,6	36	195
S340.27041	27	41	47,3	40	280
S340.30045	30	46	53,1	45	405
S340.36054	36	55	63,5	54	715
S340.42063	42	65	75	63	1170
S340.48072	48	75	86,5	72	1800

S350

- Dado prolungamento
- Extension nut

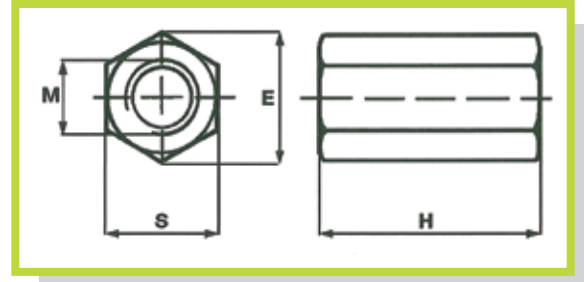

Materiale: Acciaio classe 10K.
Material: Steel class 10K.

Esempio di ordinativo : Codice
Example of purchasing order : Code

Codice/Code	M	S	E	H	gr
S350.06018	6	10	11,5	18	8
S350.08024	8	13	14,8	24	19
S350.10030	10	17	19,6	30	42
S350.12036	12	19	21,5	36	64
S350.14042	14	22	25	42	95
S350.16048	16	24	27,5	48	120
S350.18054	18	27	31	54	170
S350.20060	20	30	34,6	60	240
S350.22066	22	32	36,9	66	280
S350.24072	24	36	41,6	72	400
S350.27081	27	41	47,3	81	600
S350.30090	30	46	53,1	90	850
S350.36108	36	55	63,5	108	1470
S350.42126	42	65	75	126	2340
S350.48144	48	75	86,5	144	3600

S351

- Dado con rondella (DIN 6331)
- Nut with washer (DIN 6331)

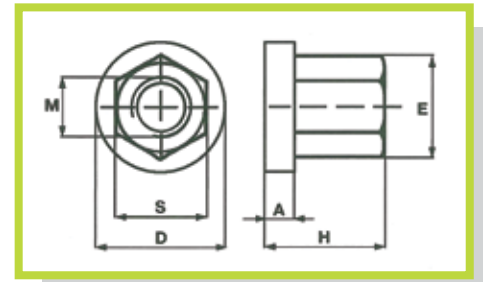

Materiale: Acciaio classe 10K.
Material: Steel class 10K.

Esempio di ordinativo : Codice
Example of purchasing order : Code

Codice/Code	M	S	E	H	A	D	gr
S351.00008	8	13	14,8	12	3,5	18	12
S351.00010	10	17	19,6	15	4	22	21
S351.00012	12	19	21,5	18	4	25	36
S351.00014	14	22	25	21	4,5	28	51
S351.00016	16	24	27,5	24	5	31	70
S351.00018	18	27	31	27	5	34	95
S351.00020	20	30	34,6	30	6	37	130
S351.00022	22	32	36,9	33	6	40	160
S351.00024	24	36	41,6	36	6	45	230
S351.00027	27	41	47,3	40	8	51	320
S351.00030	30	46	53,1	45	8	58	470
S351.00036	36	55	63,5	54	10	68	800
S351.00042	42	65	75	63	12	80	1340
S351.00048	48	75	86,5	72	14	92	2040

S360

- Tassello per cave a "T" (DIN 508 \ UNI 5531)

- Nut for T-slots (DIN 508 \ UNI 5531)

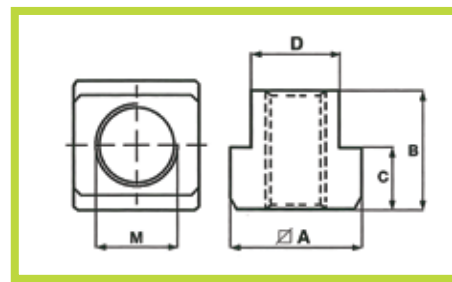

Materiale: Acciaio classe 8G.
Material: Steel class 8G.

Esempio di ordinativo : Codice
Example of purchasing order : Code

Codice/Code	M	D	A	B	C		gr	Codice/Code	M	D	A	B	C		gr
S360.06008	6	5,7	13	10	6	8	9	S360.16020	16	19,7	32	24	12	20	110
S360.08010	8	9,7	15	12	6	10	12	S360.18020	18						100
S360.08012	8	11,7	18	14	7	12	22	S360.16022	16	21,7	35	28	14	22	176
S360.10012	10						20	S360.18022	18						163
S360.08014	8	13,7	22	16	8	14	41	S360.20022	20	23,7	40	32	16	24	155
S360.10014	10						37	S360.16024	16						260
S360.12014	12	15,7	25	18	9	16	35	S360.20024	20	27,7	44	35	18	28	235
S360.08016	8						61	S360.22024	22						220
S360.10016	10	17,7	28	20	10	18	59	S360.16028	16	29,7	48	38	19	30	383
S360.12016	12						56	S360.20028	20						355
S360.14016	14	17,7	28	20	10	18	52	S360.22028	22	31,6	50	40	20	32	340
S360.08018	8						91	S360.24028	24						322
S360.10018	10	17,7	28	20	10	18	87	S360.24030	24	31,6	50	40	20	32	440
S360.12018	12						82	S360.27032	27						460
S360.14018	14	17,7	28	20	10	18	70	S360.30036	30	35,6	54	44	22	36	590
S360.16018	16						60	S360.36042	36						1010

S361

- Tassello per cave a "T" senza foro (DIN 508R \ UNI 5531)

- Blank T-Nut (DIN 508R \ UNI 5531)

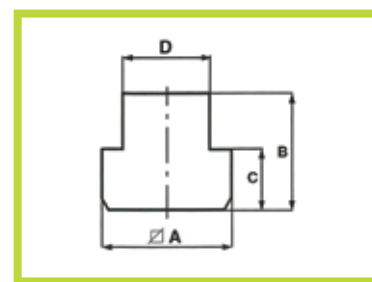

Materiale: Acciaio classe 8G.
Material: Steel class 8G.

Esempio di ordinativo : Codice
Example of purchasing order : Code

Codice/Code	D	A	B	C		gr
S361.00008	7,7	13	10	6	8	10
S361.00010	9,7	15	12	6	10	16
S361.00012	11,7	18	14	7	12	27
S361.00014	13,7	22	16	8	14	50
S361.00016	15,7	25	18	9	16	70
S361.00018	17,7	28	20	10	18	95
S361.00020	19,7	32	24	12	20	150
S361.00022	21,7	35	28	14	22	210
S361.00024	23,7	40	32	16	24	300
S361.00028	27,7	44	36	18	28	430
S361.00032	31,6	50	40	20	32	630
S361.00036	35,6	54	44	22	36	800
S361.00042	41,6	65	52	26	42	1410

S362

- Tassello per cave a "T" doppia lunghezza
- Extended nut for T-slots

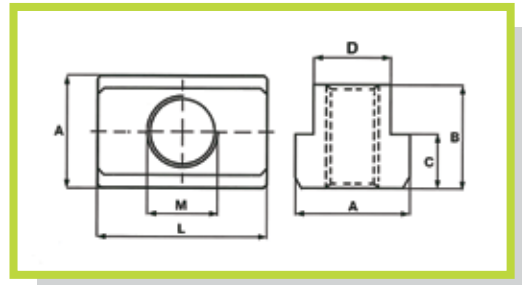

Materiale: Acciaio classe 8G.
Material: Steel class 8G.

Esempio di ordinativo : Codice
Example of purchasing order : Code

Codice/Code	M	D	L	A	B	C		gr
S362.06008	6	7,7	26	13	10	5	8	14
S362.08010	8	9,7	30	15	12	6	10	30
S362.10012	10	11,7	36	18	14	7	12	49
S362.12014	12	13,7	44	22	16	8	14	82
S362.14016	14	15,7	50	25	18	9	16	120
S362.16018	16	17,7	56	28	20	10	18	170
S362.18020	18	19,7	64	32	24	12	20	260
S362.20022	20	21,7	70	35	28	14	22	360
S362.22024	22	23,7	80	40	32	16	24	535
S362.24028	24	27,7	88	44	36	18	28	730
S362.27032	27	31,6	100	50	40	20	32	1090
S362.30036	30	35,6	108	54	44	22	36	1390

S363

- Tassello per cave romboidali
- Nut for T-slots "Rhombus"

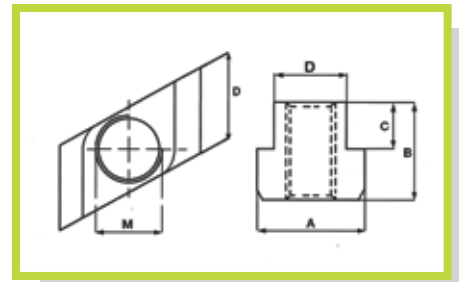

Materiale: Acciaio classe 8G.
Material: Steel class 8G.

Esempio di ordinativo : Codice
Example of purchasing order : Code

Codice/Code	M	D	A	B	C		gr
S363.10012	10	11,7	18	14	7	12	14
S363.10014	10	13,7	22	16	8	14	27
S363.12014	12	13,7	22	16	8	14	22
S363.14016	14	15,7	25	18	9	16	33
S363.10018	10	17,7	28	20	10	18	64
S363.16018	16	17,7	28	20	10	18	46
S363.16020	16	19,7	32	24	12	20	79
S363.18020	18	19,7	32	24	12	20	70
S363.16022	16	21,7	35	28	14	22	119
S363.20022	20	21,7	35	28	14	22	98
S363.16028	16	27,7	44	36	18	28	278
S363.24028	24	27,7	44	36	18	28	215
S363.30036	30	35,6	54	44	22	36	430

- Rondelle tornite

- Washers

S370

Rondelle normali tornite
Flat washers



Materiale: Acciaio classe 8G.
Material: Steel class 8G.

S380

Rondelle alte tornite
Thick washers



Materiale: Acciaio classe 8G.
Material: Steel class 8G.

S390

Rondelle larghe tornite (DIN 6340)
Broad washers (DIN 6340)



Materiale: Acciaio classe 8G.
Material: Steel class 8G.

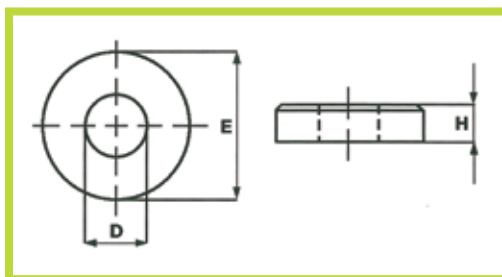

Esempio di ordinativo : Codice
Example of purchasing order : Code

Codice/Code	D	E	H	gr	Codice/Code	D	E	H	gr	Codice/Code	D	E	H	gr
S370.00006	6,4	13	3,5	3	S380.00006	6,4	20	8	17	S390.00006	6,4	17	3,5	5
S370.00008	8,4	18	4	6	S380.00008	8,4	35	8	55	S390.00008	8,4	23	4	10
S370.00010	10,5	22	4	9	S380.00010	10,5	35	8	55	S390.00010	10,5	28	4	16
S370.00012	13	28	5	20	S380.00012	13	40	8	70	S390.00012	13	35	5	35
S370.00014	15	35	6	35	S380.00014	15	40	10	85	S390.00014	15	40	5	40
S370.00016	17	35	6	35	S380.00016	17	45	10	105	S390.00016	17	45	6	70
S370.00018	19	40	6	45	S380.00018	19	45	10	100	S390.00018	19	45	6	60
S370.00020	21	40	6	45	S380.00020	21	50	12	150	S390.00020	21	50	6	73
S370.00022	23	45	8	75	S380.00022	23	50	12	140	S390.00022	23	50	8	92
S370.00024	25	45	8	70	S380.00024	25	50	12	140	S390.00024	25	60	8	170
S370.00027	28	50	10	105	S380.00027	28	50	14	145	S390.00027	28	68	10	240
S370.00030	31	50	10	95	S380.00030	31	50	14	135	S390.00030	31	68	10	230
S370.00036	37	60	12	160						S390.00036	38	80	12	350
S370.00042	43	70	12	225						S390.00042	44	100	15	670
S370.00048	49	90	12	415						S390.00048	50	100	17	920

