

STANDARD DIE SETS

CONTENTS

	Pages
- Standard die sets with centre pillars	1.03
- Standard die sets with rear pillars	1.04
- Standard die sets with diagonal pillars	1.05
- Rectangular die sets with centre pillars	1.06-1.07
- Rectangular die sets with rear pillars	1.08-1.09
- Rectangular die sets with diagonal pillars	1.10-1.11
- Rectangular die sets with four pillars	1.12-1.13
- Rectangular die sets with central pillars and ball bearing guide bushes	1.14-1.15
- Rectangular die sets with rear pillars and ball bearing guides	1.16-1.17
- Rectangular die sets with diagonal pillars and ball bearing guides	1.18-1.19
- Rectangular die sets with four pillars and ball bearing guides	1.20-1.21

In order to provide a better response to your urgent ordering requirements, we can offer you three new die set solutions:

- Standard die sets: 48-hours delivery ex works
(See pages 1.03 to 1.05).
- Rectangular die sets: 72-hours delivery ex works
(See pages 1.06 to 1.21).
- Made-to-measure die sets: according to your plans and specifications
- Special die sets: according to individual design requirements

By matching bushes and pillars, we can offer you three adjustment categories:

Category I: For tooling processing of very thin sheet metal. For very fine clearance between punch and die sections. Where clearance per side is less than 0.02 mm.

Category II: For tooling processing of sheet metal more than 0.4 mm thick
For clearance between punch and die sections from 0.02 to 0.06 mm per side.
For most applications.

Category III: For clearance between punch and die sections of 0.08 mm per side.
For automotive, forming dies.



STANDARD DIE SETS with centre pillars

D61.xxx.xxx
D71.xxx.xxx

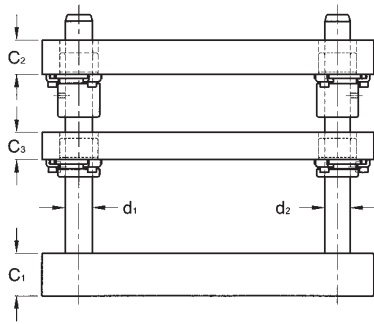

Standard die set with stripper plate
Type **D61.xxx.xxx**

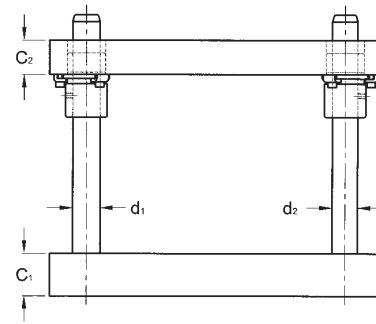

Standard die set
Type **D71.xxx.xxx**

The plates are torch-cut and stress relieved.
The guide elements can be chosen from our catalogue:

- Straight pillars P10.xxx.xxx
- Demountable pillars P2x.xxx.xxx
- Steel bushes B1x.xxx.xxx
- Bronze-plated bushes B2x.xxx.xxx

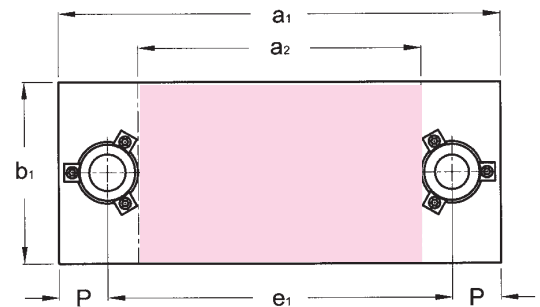

Delivery: 48 hours ex works

Examples: Die set with stripper plate: **D61.012.010**
Identical die set without stripper plate: **D71.012.010**

Ext. dimensions			C ₁ ±1	C ₂ ±1	C ₃ ±1	d ₁	d ₂	e ₁	P	Reference x = 6: with C3 x = 7: without C3
a ₂	b ₁	a ₁								
Work space										
100	80	225	32	25	25	25	24	147	39	Dx1.010.008
125		250						172		Dx1.012.008
160		285						207		Dx1.016.008
200		325						247		Dx1.020.008
100	100	225	32	25	25	25	24	147	39	Dx1.010.010
125		250						172		Dx1.012.010
160		285						207		Dx1.016.010
250		390						304		Dx1.025.010
125	125	265	40	32	28	32	30	179	43	Dx1.012.012
160		300						214		Dx1.016.012
200		340						254		Dx1.020.012
315		455						369		Dx1.031.012
160	160	300	50	40	32	32	30	214	43	Dx1.016.016
200		340						254		Dx1.020.016
250		390						304		Dx1.025.016
315		455						369		Dx1.031.016
200	200	367	40	38	40	38	38	263	52	Dx1.020.020
315		482						378		Dx1.031.020
315	250	482						378		Dx1.031.025

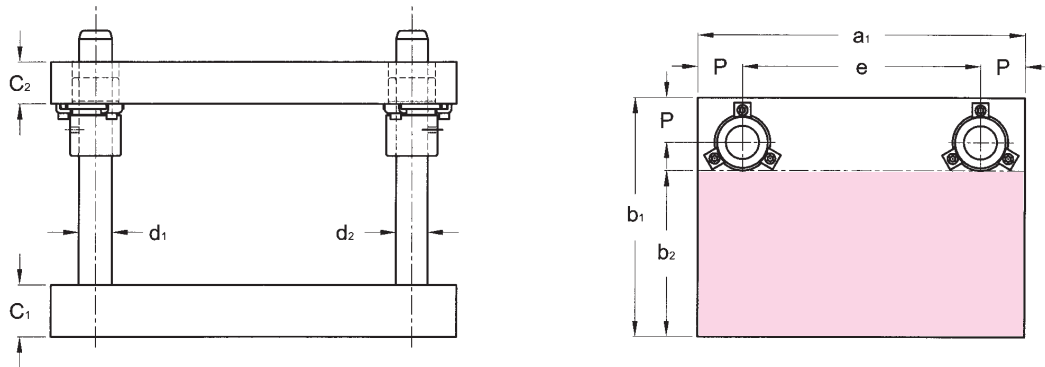

The plates are torch-cut and stress relieved.

The guide elements can be chosen from our catalogue:

- Straight pillars P10.xxx.xxx
- Demountable pillars P2x.xxx.xxx
- Steel bushes B1x.xxx.xxx
- Bronze-plated bushes B2x.xxx.xxx

Delivery: 48 hours ex works

Example: Die set with rear pillars: D72.031.010

Ext. dimensions			C ₁ ±1	C ₂ ±1	d ₁ =d ₂	e	P	Reference
a ₁	b ₂	b ₁						
Work space								
125	63	108	25	20	20	69	28	D72.012.006
160						104		D72.016.006
200						144		D72.020.006
160	80	143	32	25	25	82	39	D72.016.008
200						122		D72.020.008
250						172		D72.025.008
200	100	163	40	32	25	122	43	D72.020.010
250						172		D72.025.010
315						237		D72.031.010
200	125	195	40	32	32	114	43	D72.020.012
250						164		D72.025.012
315						229		D72.031.012
250	160	230	50	40	40	164	52	D72.025.016
315						229		D72.031.016
315	200	284	56	50	40	211	52	D72.031.020

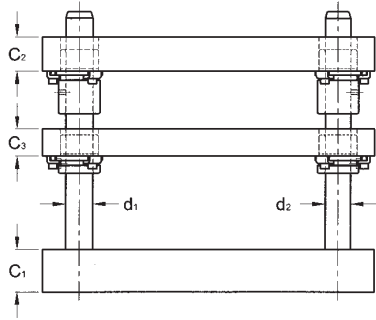

Standard die set with stripper plate, type **D63.xxx.xxx**

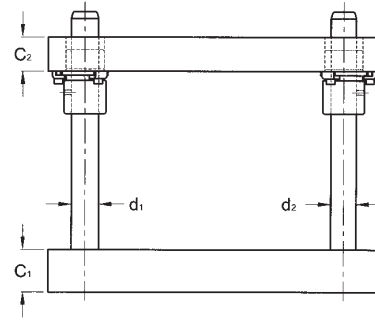

Standard die set, type **D73.xxx.xxx**

The plates are torch-cut and stress relieved.
The guide elements can be chosen from our catalogue:

- Straight pillars P10.xxx.xxx
- Demountable pillars P2x.xxx.xxx
- Steel bushes B1x.xxx.xxx
- Bronze-plated bushes B2x.xxx.xxx

Delivery: 48 hours ex works

Examples : Die set with stripper plate: **D63.024.012**
Identical die set without stripper plate: **D73.024.012**

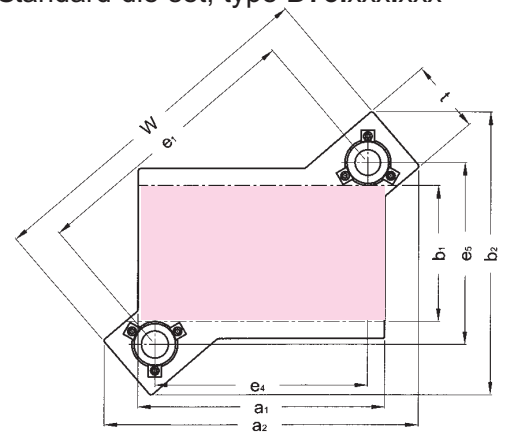

		Ext. dimensions												Reference x=6: with C3 x=7: without C3 ↓
a ₁	b ₁	a ₂	b ₂	C ₁ ±1	C ₂ ±1	C ₃ ±1	d ₁	d ₂	e ₁	e ₅ ≈	e ₄ ≈	t	w	
165	100	235	260	32	25	25	25	24	193	147	125	78	271	Dx3.016.010
200		271							218		160		296	Dx3.020.010
240		310							249		200		327	Dx3.024.010
290		357							290		250		368	Dx3.029.010
200	125	282	300	40	32	28	32	30	240	179	160	86	326	Dx3.020.012
240		322							269		200		355	Dx3.024.012
290		371							308		250		394	Dx3.029.012
355		433							363		315		449	Dx3.035.012
240	160	322	335	50	40	32	40	38	293	214	200	104	379	Dx3.024.016
290		372							329		250		415	Dx3.029.016
355		435							381		315		467	Dx3.035.016
290	200	398	410	40	40	32	40	38	363	263	250	104	467	Dx3.029.020
355		462							411		315		515	Dx3.035.020
355	250	462	460						444	313	315		548	Dx3.035.025

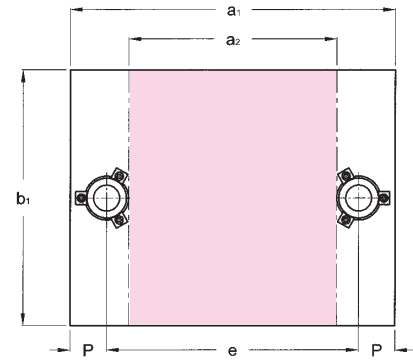
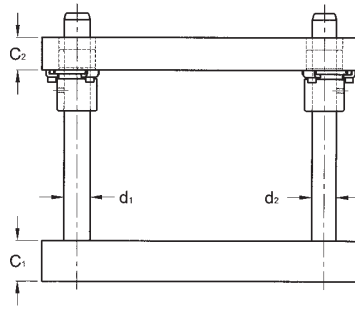
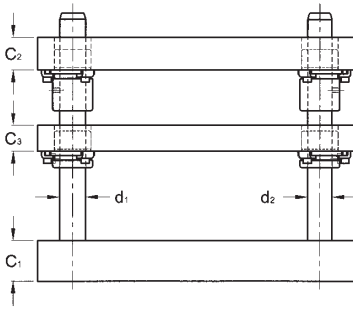

Standard assembly of bushes on underside of stripper plate.

Ext. dimensions			$C_1 \pm 1$	$C_2 \pm 1$	$C_3 \pm 1$	d_1	d_2	e	P	Reference x=8: with C3 x=9: without C3 ↓	
a_1	b_1	a_2									
250	160	127	32	32	32	25	24	174	38	Dx1.125.016	
			32	40						Dx1.225.016	
			40	32						Dx1.325.016	
			40	40						Dx1.425.016	
	200		127	32						32	Dx1.125.020
				32						40	Dx1.225.020
				40						32	Dx1.325.020
				40						40	Dx1.425.020
				250						127	32
32	40	Dx1.225.025									
40	32	Dx1.325.025									
40	40	Dx1.425.025									
315	200	171	32	32	32	32	30	225	45	Dx1.131.020	
			32	40						Dx1.231.020	
			40	32						Dx1.331.020	
			40	40						Dx1.431.020	
	250		171	32						32	Dx1.131.025
				32						40	Dx1.231.025
				40						32	Dx1.331.025
				40						40	Dx1.431.025
	315		171	40						40	Dx1.131.031
				40						50	Dx1.231.031
				50						40	Dx1.331.031
				50						50	Dx1.431.031
400	200	256	40	40	32	32	30	310	45	Dx1.140.020	
			40	50						Dx1.240.020	
			50	40						Dx1.340.020	
			50	50						Dx1.440.020	
	250		256	40						40	Dx1.140.025
				40						50	Dx1.240.025
				50						40	Dx1.340.025
				50						50	Dx1.440.025
	315		256	40						40	Dx1.140.031
				40						50	Dx1.240.031
				50						40	Dx1.340.031
				50						50	Dx1.440.031
	400		256	40						40	Dx1.140.040
				40						50	Dx1.240.040
				50						40	Dx1.340.040
				50						50	Dx1.440.040



RECTANGULAR DIE SETS with centre pillars

D81.xxx.xxx
D91.xxx.xxx

The plates are torch-cut and stress relieved.

The steel or bronze-plated steel guide elements can be chosen from our "Guide Elements" catalogue.

Delivery: **72 hours ex works**

Examples: Die set with stripper plate: D81.463.040
Identical die set without stripper plate: D91.463.040

Ext. dimensions			C ₁ ±1	C ₂ ±1	C ₃ ±1	d ₁	d ₂	e	P	Reference x=8: with C3 x=9: without C3 ↓
a ₁	b ₁	a ₂								
	Work space									
500	250	337	40	40	32	40	38	400	50	Dx1.150.025
			40	50						Dx1.250.025
			50	40						Dx1.350.025
			50	50						Dx1.450.025
	315		40	40						Dx1.150.031
			40	50						Dx1.250.031
			50	40						Dx1.350.031
			50	50						Dx1.450.031
	400		40	40						Dx1.150.040
			40	50						Dx1.250.040
			50	40						Dx1.350.040
			50	50						Dx1.450.040
500	40	40	Dx1.150.050							
	40	50	Dx1.250.050							
	50	40	Dx1.350.050							
	50	50	Dx1.450.050							
630	315	435	50	50	40	50	48	510	60	Dx1.163.031
			50	58						Dx1.263.031
			58	50						Dx1.363.031
			58	58						Dx1.463.031
	400		50	50						Dx1.163.040
			50	58						Dx1.263.040
			58	50						Dx1.363.040
			58	58						Dx1.463.040
	500		50	50						Dx1.163.050
			50	58						Dx1.263.050
			58	50						Dx1.363.050
			58	58						Dx1.463.050
630	50	50	Dx1.163.063							
	50	58	Dx1.263.063							
	58	50	Dx1.363.063							
	58	58	Dx1.463.063							
710	400	515	58	58	40	50	48	590	60	Dx1.171.040
			58	63						Dx1.271.040
			63	58						Dx1.371.040
			63	63						Dx1.471.040
	500		58	58						Dx1.171.050
			58	63						Dx1.271.050
			63	58						Dx1.371.050
			63	63						Dx1.471.050
	630		58	58						Dx1.171.063
			58	63						Dx1.271.063
			63	58						Dx1.371.063
			63	63						Dx1.471.063



RECTANGULAR DIE SETS with rear pillars

D92.XXX.XXX

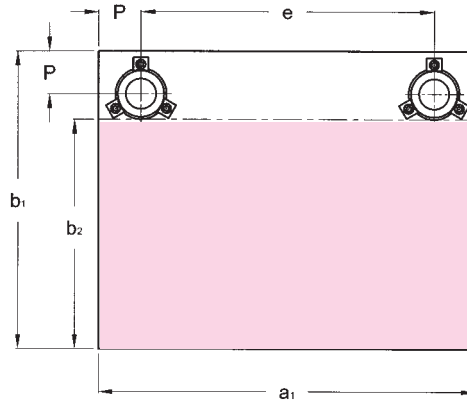
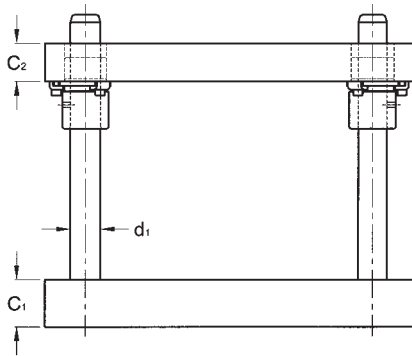

Ext. dimensions			C ₁ ±1	C ₂ ±1	d ₁	e	P	Reference	
a ₁	b ₂	b ₁							
Work space									
250	98	160	32	32	25	174	38	D92.125.016	
			32	40				D92.225.016	
			40	32				D92.325.016	
			40	40				D92.425.016	
	138	200	200	32				32	D92.125.020
				32				40	D92.225.020
				40				32	D92.325.020
				40				40	D92.425.020
				32				32	D92.125.025
188	250	250	32	40	D92.225.025				
			40	32	D92.325.025				
			40	40	D92.425.025				
			40	40	D92.425.025				
315	128	200	32	32	32	225	45	D92.131.020	
			32	40				D92.231.020	
			40	32				D92.331.020	
			40	40				D92.431.020	
	178	250	250	32				32	D92.131.025
				32				40	D92.231.025
				40				32	D92.331.025
				40				40	D92.431.025
				40				40	D92.431.025
243	315	315	40	40	D92.131.031				
			40	50	D92.231.031				
			50	40	D92.331.031				
			50	50	D92.431.031				
			50	50	D92.431.031				
400	128	200	40	40	32	310	45	D92.140.020	
			40	50				D92.240.020	
			50	40				D92.340.020	
			50	50				D92.440.020	
	178	250	250	40				40	D92.140.025
				40				50	D92.240.025
				50				40	D92.340.025
				50				50	D92.440.025
				50				50	D92.440.025
	243	315	315	40				40	D92.140.031
				40				50	D92.240.031
				50				40	D92.340.031
				50				50	D92.440.031
318	400	400	40	40	D92.140.040				
			40	50	D92.240.040				
			50	40	D92.340.040				
			50	50	D92.440.040				



RECTANGULAR DIE SETS with rear pillars

D92.XXX.XXX

The plates are torch-cut and stress relieved.

The steel or bronze-plated steel guide elements can be chosen from our "Guide Elements" catalogue.

Delivery: **72 hours ex works**

Example : Rectangular die set with rear pillars: **D92.450.050**

Ext. dimensions			C ₁ ±1	C ₂ ±1	d ₁	e	P	Reference
a ₁	b ₂	b ₁						
Work space								
500	168	250	40	40	40	400	50	D92.150.025
			40	50				D92.250.025
			50	40				D92.350.025
			50	50				D92.450.025
	233	315	40	40				D92.150.031
			40	50				D92.250.031
			50	40				D92.350.031
			50	50				D92.450.031
	318	400	40	40				D92.150.040
			40	50				D92.250.040
			50	40				D92.350.040
			50	50				D92.450.040
418	500	40	40	D92.150.050				
		40	50	D92.250.050				
		50	40	D92.350.050				
		50	50	D92.450.050				
630	217	315	50	50	D92.163.031			
			50	58	D92.263.031			
			58	50	D92.363.031			
			58	58	D92.463.031			
	302	400	50	50	D92.163.040			
			50	58	D92.263.040			
			58	50	D92.363.040			
			58	58	D92.463.040			
	402	500	50	50	D92.163.050			
			50	58	D92.263.050			
			58	50	D92.363.050			
			58	58	D92.463.050			
532	630	50	50	D92.163.063				
		50	58	D92.263.063				
		58	50	D92.363.063				
		58	58	D92.463.063				
710	302	400	58	58	D92.171.040			
			58	63	D92.271.040			
			63	58	D92.371.040			
			63	63	D92.471.040			
	402	500	58	58	D92.171.050			
			58	63	D92.271.050			
			63	58	D92.371.050			
			63	63	D92.471.050			
	532	630	58	58	D92.171.063			
			58	63	D92.271.063			
			63	58	D92.371.063			
			63	63	D92.471.063			

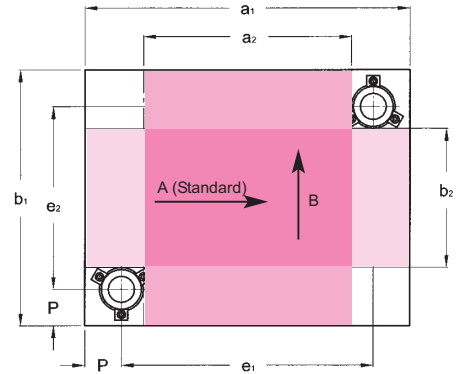
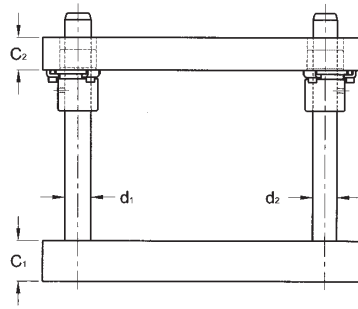
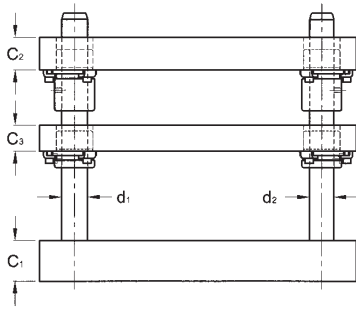

Standard assembly of bushes on underside of stripper plate.

Ext. dimensions				C ₁ ±1	C ₂ ±1	C ₃ ±1	d ₁	d ₂	e ₁	e ₂	P	Reference x=8: with C3 x=9: without C3
Work space, direction A		Work space, direction B										
a ₁	b ₂	b ₁	a ₂									
250	37	160	127	32	32	32	25	24	174	84	38	Dx3.125.016
				32	40							Dx3.225.016
				40	32							Dx3.325.016
				40	40							Dx3.425.016
	77	200		200	32					32		Dx3.125.020
					32					40		Dx3.225.020
					40					32		Dx3.325.020
					40					40		Dx3.425.020
	127	250		250	32					32		Dx3.125.025
					32					40		Dx3.225.025
					40					32		Dx3.325.025
					40					40		Dx3.425.025
315	56	200	171	32	32	32	32	30	225	110	45	Dx3.131.020
				32	40							Dx3.231.020
				40	32							Dx3.331.020
				40	40							Dx3.431.020
	106	250		250	32					32		Dx3.131.025
					32					40		Dx3.231.025
					40					32		Dx3.331.025
					40					40		Dx3.431.025
	171	315		315	40					40		Dx3.131.031
					40					50		Dx3.231.031
					50					40		Dx3.331.031
					50					50		Dx3.431.031
400	56	200	256	40	40	32	32	30	310	110	45	Dx3.140.020
				40	50							Dx3.240.020
				50	40							Dx3.340.020
				50	50							Dx3.440.020
	106	250		250	40					40		Dx3.140.025
					40					50		Dx3.240.025
					50					40		Dx3.340.025
					50					50		Dx3.440.025
	171	315		315	40					40		Dx3.140.031
					40					50		Dx3.240.031
					50					40		Dx3.340.031
					50					50		Dx3.440.031
256	400	400	40	40	Dx3.140.040							
			40	50	Dx3.240.040							
			50	40	Dx3.340.040							
			50	50	Dx3.440.040							



RECTANGULAR DIE SETS with diagonal pillars

D83.xxx.xxx
D93.xxx.xxx

The plates are torch-cut and stress relieved.

The steel or bronze-plated steel guide elements can be chosen from our "Guide Elements" catalogue.

Delivery : **72 hours ex works**

Examples : Die set with stripper plate: D83.450.031
 Identical die set without stripper plate: D93.450.031

Ext. dimensions				C ₁ ±1	C ₂ ±1	C ₃ ±1	d ₁	d ₂	e ₁	e ₂	P	Reference x=8: with C3 x=9: without C3 ↓ C3							
Work space, direction A		Work space, direction B																	
a ₁	b ₂	b ₁	a ₂																
500	87	250	337	40	40	32	40	38	400	150	50	Dx3.150.025 Dx3.250.025 Dx3.350.025 Dx3.450.025							
				40	50							Dx3.150.031 Dx3.250.031 Dx3.350.031 Dx3.450.031							
				50	40							Dx3.150.040 Dx3.250.040 Dx3.350.040 Dx3.450.040							
				50	50							Dx3.150.050 Dx3.250.050 Dx3.350.050 Dx3.450.050							
	152	315		40	40					50		50	215	Dx3.150.031 Dx3.250.031 Dx3.350.031 Dx3.450.031					
				40	50					40		40	300	Dx3.150.040 Dx3.250.040 Dx3.350.040 Dx3.450.040					
				50	40					50		50	400	Dx3.150.050 Dx3.250.050 Dx3.350.050 Dx3.450.050					
				50	50														
	237	400		40	40					50		50	380	Dx3.150.031 Dx3.250.031 Dx3.350.031 Dx3.450.031					
				40	50					40		40	510	Dx3.150.040 Dx3.250.040 Dx3.350.040 Dx3.450.040					
				50	40					50		50							
				50	50														
	337	500		40	40					50		50	510	Dx3.150.031 Dx3.250.031 Dx3.350.031 Dx3.450.031					
				40	50					40		40							
				50	40					50		50							
				50	50														
630	120	315	435	50	50	40	50	48	510	195	60	Dx3.163.031 Dx3.263.031 Dx3.363.031 Dx3.463.031							
				50	58							Dx3.163.040 Dx3.263.040 Dx3.363.040 Dx3.463.040							
				58	50							Dx3.163.050 Dx3.263.050 Dx3.363.050 Dx3.463.050							
				58	58							Dx3.163.063 Dx3.263.063 Dx3.363.063 Dx3.463.063							
	205	400		50	50					50		50	280	Dx3.163.031 Dx3.263.031 Dx3.363.031 Dx3.463.031					
				50	58					50		50	380	Dx3.163.040 Dx3.263.040 Dx3.363.040 Dx3.463.040					
				58	50					50		50	510	Dx3.163.050 Dx3.263.050 Dx3.363.050 Dx3.463.050					
				58	58														
	305	500		50	50					50		50							
				50	58					50		50							
				58	50					50		50							
				58	58														
	435	630		50	50					50		50							
				50	58					50		50							
				58	50					50		50							
				58	58														
710	205	400	515	58	58	40	50	48	590	280	60	Dx3.171.040 Dx3.271.040 Dx3.371.040 Dx3.471.040							
				58	63							Dx3.171.050 Dx3.271.050 Dx3.371.050 Dx3.471.050							
				63	58							Dx3.171.063 Dx3.271.063 Dx3.371.063 Dx3.471.063							
				63	63														
	305	500		58	58					58		58	380	Dx3.171.040 Dx3.271.040 Dx3.371.040 Dx3.471.040					
				58	63					58		58	510	Dx3.171.050 Dx3.271.050 Dx3.371.050 Dx3.471.050					
				63	58					58		58							
				63	63														
	435	630		58	58					58		58							
				58	63					58		58							
				63	58					58		58							
				63	63														

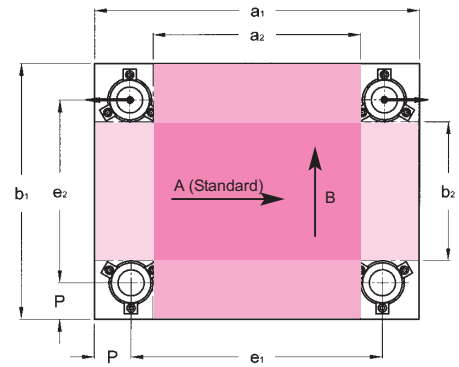
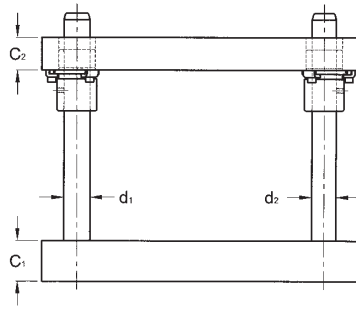
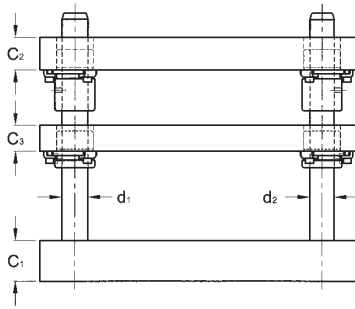

Standard assembly of bushes on underside of stripper plate.

Ext. dimensions				C ₁ ±1	C ₂ ±1	C ₃ ±1	d ₁	e ₁	e ₂	P	Reference x=8: with C3 x=9: without C3
Work space, direction A		Work space, direction B									
a ₁	b ₂	b ₁	a ₂								
250	37	160	127	32	32	32	25	174	84	38	Dx4.125.016
				32	40						Dx4.225.016
				40	32						Dx4.325.016
				40	40						Dx4.425.016
	77	200		127	32				32		Dx4.125.020
					32				40		Dx4.225.020
					40				32		Dx4.325.020
					40				40		Dx4.425.020
	127	250		192	32				32		Dx4.125.025
					32				40		Dx4.225.025
					40				32		Dx4.325.025
					40				40		Dx4.425.025
315	77	200	192	32	32	32	25	239	124	38	Dx4.131.020
				32	40						Dx4.231.020
				40	32						Dx4.331.020
				40	40						Dx4.431.020
	127	250		192	32				32		Dx4.131.025
					32				40		Dx4.231.025
					40				32		Dx4.331.025
					40				40		Dx4.431.025
	192	315		277	40				40		Dx4.131.031
					40				50		Dx4.231.031
					50				40		Dx4.331.031
					50				50		Dx4.431.031
400	77	200	277	40	40	32	25	324	124	38	Dx4.140.020
				40	50						Dx4.240.020
				50	40						Dx4.340.020
				50	50						Dx4.440.020
	127	250		256	40				40		Dx4.140.025
					40				50		Dx4.240.025
					50				40		Dx4.340.025
					50				50		Dx4.440.025
	171	315		256	40				40		Dx4.140.031
					40				50		Dx4.240.031
					50				40		Dx4.340.031
					50				50		Dx4.440.031
256	400	256	40	40	Dx4.140.040						
			40	50	Dx4.240.040						
			50	40	Dx4.340.040						
			50	50	Dx4.440.040						



RECTANGULAR DIE SETS with four pillars

D84.xxx.xxx
D94.xxx.xxx

The plates are torch-cut and stress relieved.

The steel or bronze-plated steel guide elements can be chosen from our “Guide Elements” catalogue.

The two rear pillars are offset by two mm towards the outside for foolproofing.

Delivery: 72 hours ex works

Examples: Die set with stripper plate: D84.450.031
Identical die set without stripper plate: D94.450.031

Ext. dimensions				C ₁ ±1	C ₂ ±1	C ₃ ±1	d ₁	e ₁	e ₂	P	Reference x=8: with C3 x=9: without ↓ C3
Work space, direction A		Work space, direction B									
a ₁	b ₂	b ₁	a ₂								
500	106	250	356	40	40	32	32	410	160	45	Dx4.150.025
				40	50						Dx4.250.025
				50	40						Dx4.350.025
				50	50						Dx4.450.025
	171	315		40	40				Dx4.150.031		
				40	50				Dx4.250.031		
				50	40				Dx4.350.031		
				50	50				Dx4.450.031		
	256	400		40	40				Dx4.150.040		
				40	50				Dx4.250.040		
				50	40				Dx4.350.040		
				50	50				Dx4.450.040		
356	500	40	40	Dx4.150.050							
		40	50	Dx4.250.050							
		50	40	Dx4.350.050							
		50	50	Dx4.450.050							
630	152	315	467	50	50	40	40	530	215	50	Dx4.163.031
				50	58						Dx4.263.031
				58	50						Dx4.363.031
				58	58						Dx4.463.031
	237	400		50	50				Dx4.163.040		
				50	58				Dx4.263.040		
				58	50				Dx4.363.040		
				58	58				Dx4.463.040		
	337	500		50	50				Dx4.163.050		
				50	58				Dx4.263.050		
				58	50				Dx4.363.050		
				58	58				Dx4.463.050		
467	630	50	50	Dx4.163.063							
		50	58	Dx4.263.063							
		58	50	Dx4.363.063							
		58	58	Dx4.463.063							
710	205	400	515	58	58	40	50	590	280	60	Dx4.171.040
				58	63						Dx4.271.040
				63	58						Dx4.371.040
				63	63						Dx4.471.040
	305	500		58	58				Dx4.171.050		
				58	63				Dx4.271.050		
				63	58				Dx4.371.050		
				63	63				Dx4.471.050		
	435	630		58	58				Dx4.171.063		
				58	63				Dx4.271.063		
				63	58				Dx4.371.063		
				63	63				Dx4.471.063		



RECTANGULAR DIE SETS

with central pillars and ball bearing
guide bushes

D86.xxx.xxx

D96.xxx.xxx

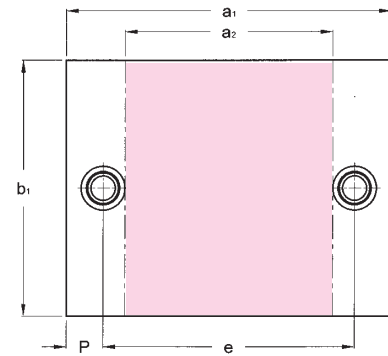
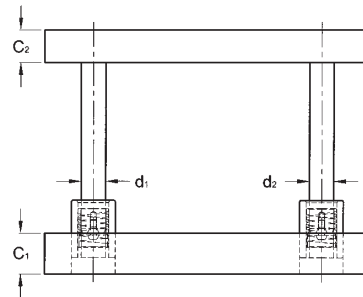
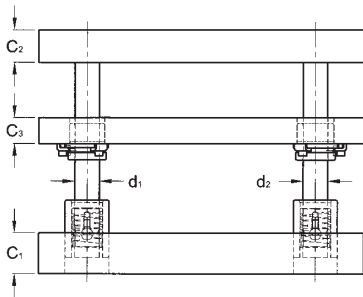

Standard assembly of bushes on stripper plate:
 - on underside for demountable guide bushes (B1x.xxx.xxx and B2x.xxx.xxx)
 - on top side for ball bearing guide bushes (B4x.xxx.xxx)

Ext. dimensions			C ₁ ±1	C ₂ ±1	C ₃ ±1	d ₁	d ₂	e	P	Reference x=8: with C3 x=9: without C3 ↓	
a ₁	b ₁	a ₂									
250	160	120	32	32	32	25	24	165	42.5	Dx6.125.016 Dx6.225.016 Dx6.325.016 Dx6.425.016	
			32	40							
			40	32							
			40	40							
	200		32	32							
			32	40							
250	250	40	32								
		40	40								
		40	32								
		40	40								
315	200	170	32	32	32	32	30	224	45.5	Dx6.131.020 Dx6.231.020 Dx6.331.020 Dx6.431.020	
			32	40							
			40	32							
			40	40							
	250		250	32							32
				32							40
				40							32
				40							40
	315		315	40							40
				40							50
				50							40
				50							50
400	200	255	40	40	32	32	30	309	45.5	Dx6.140.020 Dx6.240.020 Dx6.340.020 Dx6.440.020	
			40	50							
			50	40							
			50	50							
	250		250	40							40
				40							50
				50							40
				50							50
	315		315	40							40
				40							50
				50							40
				50							50
	400		400	40							40
				40							50
				50							40
				50							50



RECTANGULAR DIE SETS with central pillars and ball bearing guide bushes

D86.xxx.xxx
D96.xxx.xxx

The plates are torch-cut and stress relieved.

The guide elements with ball bearings (bush B30.xxx.xxx) can be chosen from our "Guide Elements" catalogue.

Please note: The work space is reduced if B40 or B42 bushes are used (see pages 3.09 and 3.10 - position of clamps - dimensions Q1 and Q2).

Delivery: 72 hours ex works

Examples: Die set with stripper plate: D86.463.040
Identical die set without stripper plate: D96.463.040

Ext. dimensions			C ₁ ±1	C ₂ ±1	C ₃ ±1	d ₁	d ₂	e	P	Reference x=8: with C3 x=9: without C3 ↓			
a ₁	b ₁	a ₂											
500	250	330	40	40	32	40	38	395	52.5	Dx6.150.025 Dx6.250.025 Dx6.350.025 Dx6.450.025			
			40	50									
			50	40									
			50	50									
	315		40	40							40	50	Dx6.150.031 Dx6.250.031 Dx6.350.031 Dx6.450.031
			40	50									
			50	40									
			50	50									
	400		40	40							40	50	Dx6.150.040 Dx6.250.040 Dx6.350.040 Dx6.450.040
			40	50									
			50	40									
			50	50									
500	40	40	40	50	Dx6.150.050 Dx6.250.050 Dx6.350.050 Dx6.450.050								
	40	50											
	50	40											
	50	50											
630	315	429	50	50	40	50	48	510	60	Dx6.163.031 Dx6.263.031 Dx6.363.031 Dx6.463.031			
			50	58									
			58	50									
			58	58									
	400		50	50							50	58	Dx6.163.040 Dx6.263.040 Dx6.363.040 Dx6.463.040
			50	58									
			58	50									
			58	58									
	500		50	50							50	58	Dx6.163.050 Dx6.263.050 Dx6.363.050 Dx6.463.050
			50	58									
			58	50									
			58	58									
630	50	50	50	58	Dx6.163.063 Dx6.263.063 Dx6.363.063 Dx6.463.063								
	50	58											
	58	50											
	58	58											
710	400	509	58	58	40	50	48	590	60	Dx6.171.040 Dx6.271.040 Dx6.371.040 Dx6.471.040			
			58	63									
			63	58									
			63	63									
	500		58	58							58	63	Dx6.171.050 Dx6.271.050 Dx6.371.050 Dx6.471.050
			58	63									
			63	58									
			63	63									
	630		58	58							58	63	Dx6.171.063 Dx6.271.063 Dx6.371.063 Dx6.471.063
			58	63									
			63	58									
			63	63									

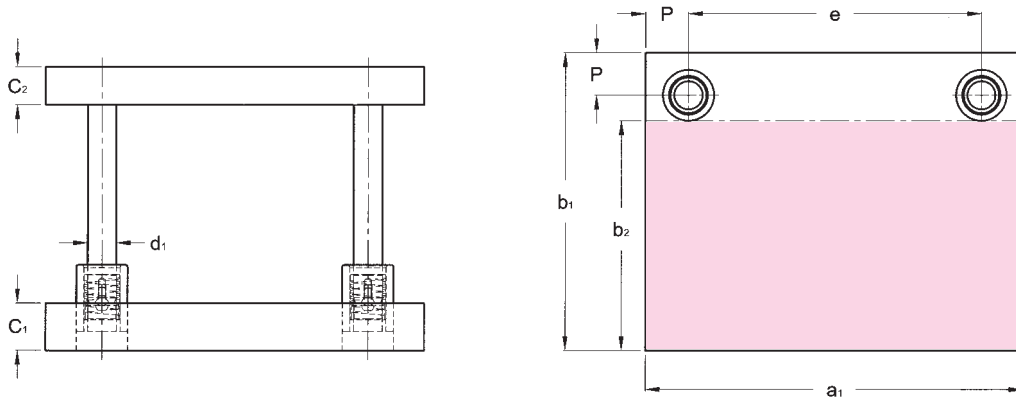

Ext. dimensions			$C_1 \pm 1$	$C_2 \pm 1$	d_1	e	P	Reference				
a_1	b_2	b_1										
Work space												
250	93	160	32	32	32	170	40	D97.125.016				
			32	40				D97.225.016				
			40	32				D97.325.016				
			40	40				D97.425.016				
	133	200	200	32				32	D97.125.020			
				32				40	D97.225.020			
				40				32	D97.325.020			
				40				40	D97.425.020			
				32				32	D97.125.025			
183	250	250	32	40	D97.225.025							
			40	32	D97.325.025							
			40	40	D97.425.025							
			40	40	D97.425.025							
315	128	200	32	32	32	225	45	D97.131.020				
			32	40				D97.231.020				
			40	32				D97.331.020				
			40	40				D97.431.020				
	178	250	250	32				32	D97.131.025			
				32				40	D97.231.025			
				40				32	D97.331.025			
				40				40	D97.431.025			
	243	315	315	40				40	D97.131.031			
				40				50	D97.231.031			
				50				40	D97.331.031			
				50				50	D97.431.031			
400	128	200	40	40	32	310	45	D97.140.020				
			40	50				D97.240.020				
			50	40				D97.340.020				
			50	50				D97.440.020				
	178	250	250	40				40	D97.140.025			
				40				50	D97.240.025			
				50				40	D97.340.025			
				50				50	D97.440.025			
	230	315	315	40				40	40	295	52.5	D97.140.031
				40				50				D97.240.031
				50				40				D97.340.031
				50				50				D97.440.031
	315	400	400	40				40				D97.140.040
				40				50				D97.240.040
				50				40				D97.340.040
				50				50				D97.440.040



RECTANGULAR DIE SETS with rear pillars and ball bearing guides

D97.xxx.xxx

The plates are torch-cut and stress relieved.

The guide elements with ball bearings (bush B30.xxx.xxx) can be chosen from our "Guide Elements" catalogue.

Please note: The work space is reduced if B40 bushes are used (see pages 3.09 - position of clamps - dimensions Q1 and Q2).

Delivery: **72 hours ex works**

Example: Rectangular stock die set with: D97.350.040
rear ball bearing guides

Ext. dimensions			C ₁ ±1	C ₂ ±1	d ₁	e	P	Reference
a ₁	b ₂	b ₁						
Work space								
500	157	250	40	40	40	395	52.5	D97.150.025
			40	50				D97.250.025
			50	40				D97.350.025
			50	50				D97.450.025
	222	315	40	40				D97.150.031
			40	50				D97.250.031
			50	40				D97.350.031
			50	50				D97.450.031
	307	400	40	40				D97.150.040
			40	50				D97.250.040
			50	40				D97.350.040
			50	50				D97.450.040
407	500	40	40	D97.150.050				
		40	50	D97.250.050				
		50	40	D97.350.050				
		50	50	D97.450.050				
630	206	315	50	50	50	510	60	D97.163.031
			50	58				D97.263.031
			58	50				D97.363.031
			58	58				D97.463.031
	291	400	50	50				D97.163.040
			50	58				D97.263.040
			58	50				D97.363.040
			58	58				D97.463.040
	391	500	50	50				D97.163.050
			50	58				D97.263.050
			58	50				D97.363.050
			58	58				D97.463.050
521	630	50	50	D97.163.063				
		50	58	D97.263.063				
		58	50	D97.363.063				
		58	58	D97.463.063				
710	291	400	58	58	50	590	60	D97.171.040
			58	63				D97.271.040
			63	58				D97.371.040
			63	63				D97.471.040
	391	500	58	58				D97.171.050
			58	63				D97.271.050
			63	58				D97.371.050
			63	63				D97.471.050
	521	630	58	58				D97.171.063
			58	63				D97.271.063
			63	58				D97.371.063
			63	63				D97.471.063



RECTANGULAR DIE SETS with diagonal pillars and ball bearing guides

D88.xxx.xxx
D98.xxx.xxx

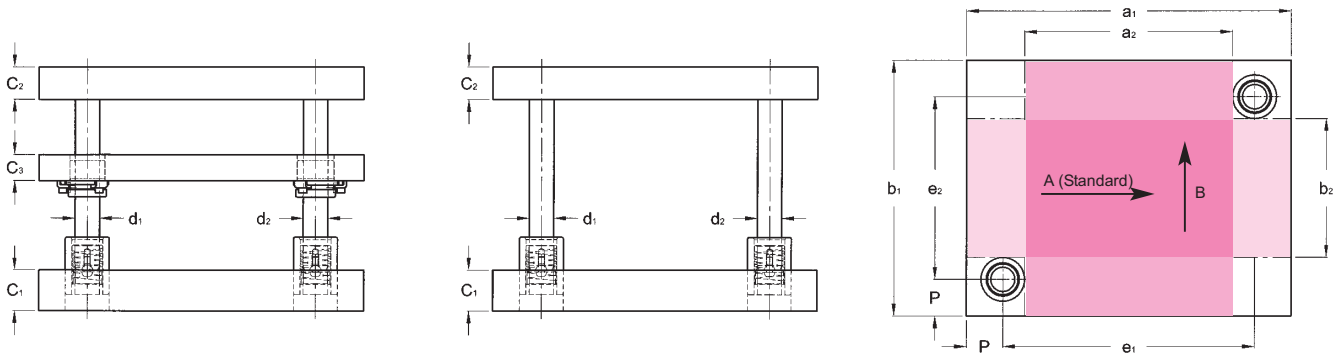

Standard assembly of bushes on stripper plate:
 - on underside for demountable guide bushes (B1x.xxx.xxx and B2x.xxx.xxx)
 - on top side for ball bearing guide bushes (B4x.xxx.xxx)

Ext. dimensions				C ₁ ±1	C ₂ ±1	C ₃ ±1	d ₁	d ₂	e ₁	e ₂	P	Reference x=8: with C3 x=9: without C3													
Work space, direction A		Work space, direction B																							
a ₁	b ₂	b ₁	a ₂																						
250	30	160	120	32	32	32	25	24	165	75	42.5	Dx8.125.016 Dx8.225.016 Dx8.325.016 Dx8.425.016													
				32	40																				
	40	32																							
	40	40																							
	32	32																							
	32	40																							
40	32																								
250	70	200	120	32	32	32	25	24	165	115	42.5	Dx8.125.020 Dx8.225.020 Dx8.325.020 Dx8.425.020													
				32	40																				
	40	32																							
	40	40																							
	32	32																							
	32	40																							
40	32																								
250	120	250	120	32	32	32	25	24	165	165	42.5	Dx8.125.025 Dx8.225.025 Dx8.325.025 Dx8.425.025													
				32	40																				
	40	32																							
	40	40																							
	32	32																							
	32	40																							
40	32																								
315	56	200	171	32	32	32	32	30	225	110	45	Dx8.131.020 Dx8.231.020 Dx8.331.020 Dx8.431.020													
				32	40																				
	40	32																							
	40	40																							
	32	32																							
	32	40																							
40	32																								
315	106	250	171	32	32	32	32	30	225	160	45	Dx8.131.025 Dx8.231.025 Dx8.331.025 Dx8.431.025													
				32	40																				
	40	32																							
	40	40																							
	32	32																							
	32	40																							
40	32																								
315	171	315	171	40	40	32	32	30	225	225	45	Dx8.131.031 Dx8.231.031 Dx8.331.031 Dx8.431.031													
				40	50																				
	50	40																							
	50	50																							
	40	40																							
	40	50																							
50	40																								
400	56	200	260	40	40	32	32	30	310	110	45	Dx8.140.020 Dx8.240.020 Dx8.340.020 Dx8.440.020													
				40	50																				
				50	40																				
				50	50																				
	106	250		250	260					40			40	32	32	30	160	45	Dx8.140.025 Dx8.240.025 Dx8.340.025 Dx8.440.025						
										40			50												
										50			40												
										50			50												
	171	315		315						260			40				40			32	32	30	225	45	Dx8.140.031 Dx8.240.031 Dx8.340.031 Dx8.440.031
													40				50								
													50				40								
													50				50								
256	400	400	260	40		40	32	32	30		310	45	Dx8.140.040 Dx8.240.040 Dx8.340.040 Dx8.440.040												
				40		50																			
				50		40																			
				50		50																			



RECTANGULAR DIE SETS with diagonal pillars and ball bearing guides

D88.xxx.xxx
D98.xxx.xxx

The plates are torch-cut and stress relieved.

The guide elements with ball bearings (bush B30.xxx.xxx) can be chosen from our "Guide Elements" catalogue.

Please note: The work space is reduced if B40 or B42 bushes are used (see pages 3.09 and 3.10 - position of clamps - dimensions Q1 and Q2).

Delivery: 72 hours ex works

Examples: Die set with stripper plate: D88.125.016
Identical die set without stripper plate: D98.125.016

Ext. dimensions				C ₁ ±1	C ₂ ±1	C ₃ ±1	d ₁	d ₂	e ₁	e ₂	P	Reference x=8: with C3 x=9: without C3 ↓ C3							
Work space, direction A		Work space, direction B																	
a ₁	b ₂	b ₁	a ₂																
500	80	250	330	40	40	32	40	38	395	145	52.5	Dx8.150.025 Dx8.250.025 Dx8.350.025 Dx8.450.025							
				40	50														
				50	40														
				50	50														
	145	315		315	40					40			40	50	40	50	210	52.5	Dx8.150.031 Dx8.250.031 Dx8.350.031 Dx8.450.031
					40					50									
					50					40									
					50					50									
	230	400		400	40					40			40	50	40	50	295	52.5	Dx8.150.040 Dx8.250.040 Dx8.350.040 Dx8.450.040
					40					50									
					50					40									
					50					50									
330	500	500	40	40	40	50	40	50	395	52.5	Dx8.150.050 Dx8.250.050 Dx8.350.050 Dx8.450.050								
			40	50															
			50	40															
			50	50															
630	114	315	429	50	50	40	50	48	510	195	60	Dx8.163.031 Dx8.263.031 Dx8.363.031 Dx8.463.031							
				50	58														
				58	50														
				58	58														
	199	400		400	50					50			40	50	48	510	280	60	Dx8.163.040 Dx8.263.040 Dx8.363.040 Dx8.463.040
					50					58									
					58					50									
					58					58									
	299	500		500	50					50			40	50	48	510	380	60	Dx8.163.050 Dx8.263.050 Dx8.363.050 Dx8.463.050
					50					58									
					58					50									
					58					58									
429	630	630	50	50	40	50	48	510	510	60	Dx8.163.063 Dx8.263.063 Dx8.363.063 Dx8.463.063								
			50	58															
			58	50															
			58	58															
710	199	400	509	58	58	40	50	48	590	280	60	Dx8.171.040 Dx8.271.040 Dx8.371.040 Dx8.471.040							
				58	63														
				63	58														
				63	63														
	299	500		500	58					58			40	50	48	590	380	60	Dx8.171.050 Dx8.271.050 Dx8.371.050 Dx8.471.050
					58					63									
					63					58									
					63					63									
	429	630		630	58					58			40	50	48	590	510	60	Dx8.171.063 Dx8.271.063 Dx8.371.063 Dx8.471.063
					58					63									
					63					58									
					63					63									



RECTANGULAR DIE SETS

with four pillars and ball bearing guides

D89.XXX.XXX

D99.XXX.XXX

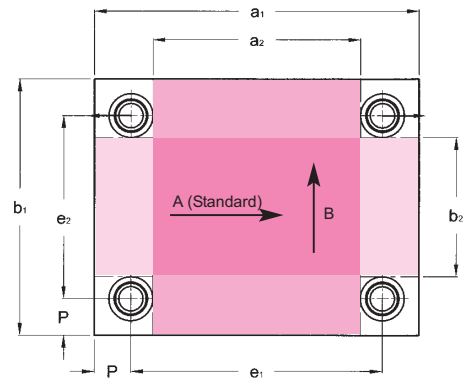
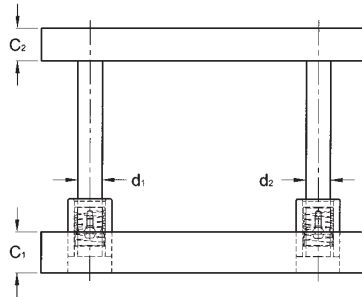
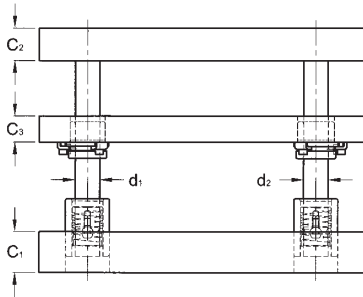

Standard assembly of bushes on stripper plate:

- on underside for demountable guide bushes (B1x.xxx.xxx and B2x.xxx.xxx)
- on top side for ball bearing guide bushes (B4x.xxx.xxx)

Ext. dimensions				C ₁ ±1	C ₂ ±1	C ₃ ±1	d ₁	e ₁	e ₂	P	Reference x=8: with C3 x=9: without C3
Work space, direction A		Work space, direction B									
a ₁	b ₂	b ₁	a ₂								
250	30	160	120	32	32	32	25	165	75	42.5	Dx9.125.016
				32	40						Dx9.225.016
				40	32						Dx9.325.016
				40	40						Dx9.425.016
	70	200		120	32				32		Dx9.125.020
					32				40		Dx9.225.020
					40				32		Dx9.325.020
					40				40		Dx9.425.020
	120	250		250	32				32		Dx9.125.025
					32				40		Dx9.225.025
					40				32		Dx9.325.025
					40				40		Dx9.425.025
315	70	200	185	32	32	32	25	230	115	42.5	Dx9.131.020
				32	40						Dx9.231.020
				40	32						Dx9.331.020
				40	40						Dx9.431.020
	120	250		315	32				32		Dx9.131.025
					32				40		Dx9.231.025
					40				32		Dx9.331.025
					40				40		Dx9.431.025
	185	315		270	40				40		Dx9.131.031
					40				50		Dx9.231.031
					50				40		Dx9.331.031
					50				50		Dx9.431.031
400	70	200	270	40	40	32	25	315	115	42.5	Dx9.140.020
				40	50						Dx9.240.020
				50	40						Dx9.340.020
				50	50						Dx9.440.020
	120	250		400	40				40		Dx9.140.025
					40				50		Dx9.240.025
					50				40		Dx9.340.025
					50				50		Dx9.440.025
	165	315		250	40				40		Dx9.140.031
					40				50		Dx9.240.031
					50				40		Dx9.340.031
					50				50		Dx9.440.031
250	400	250	40	40	Dx9.140.040						
			40	50	Dx9.240.040						
			50	40	Dx9.340.040						
			50	50	Dx9.440.040						



RECTANGULAR DIE SETS

with four pillars and ball bearing guides

D89.xxx.xxx
D99.xxx.xxx

The plates are torch-cut and stress relieved.

The guide elements with ball bearings (bush B30.xxx.xxx) can be chosen from our "Guide Elements" catalogue.

The two rear pillars are offset by three mm towards the outside for foolproofing.

Please note: The work space is reduced if B40 or B42 bushes are used (See pages 3.09 and 3.10 - position of clamps - dimensions Q1 and Q2).

Delivery: 72 hours ex works

Examples: Die set with stripper plate: D89.125.016
Identical die set without stripper plate: D99.125.016

Ext. dimensions				C ₁ ±1	C ₂ ±1	C ₃ ±1	d ₁	e ₁	e ₂	P	Reference x=8: with C3 x=9: without ↓ C3
Work space, direction A		Work space, direction B									
a ₁	b ₂	b ₁	a ₂								
500	100	250	350	40	40	32	32	404	154	48	Dx9.150.025
				40	50						Dx9.250.025
				50	40						Dx9.350.025
				50	50						Dx9.450.025
	165	315		40	40				Dx9.150.031		
				40	50				Dx9.250.031		
				50	40				Dx9.350.031		
				50	50				Dx9.450.031		
	250	400		40	40				Dx9.150.040		
				40	50				Dx9.250.040		
				50	40				Dx9.350.040		
				50	50				Dx9.450.040		
350	500	40	40	Dx9.150.050							
		40	50	Dx9.250.050							
		50	40	Dx9.350.050							
		50	50	Dx9.450.050							
630	140	315	455	50	50	40	40	520	205	55	Dx9.163.031
				50	58						Dx9.263.031
				58	50						Dx9.363.031
				58	58						Dx9.463.031
	225	400		50	50				Dx9.163.040		
				50	58				Dx9.263.040		
				58	50				Dx9.363.040		
				58	58				Dx9.463.040		
	325	500		50	50				Dx9.163.050		
				50	58				Dx9.263.050		
				58	50				Dx9.363.050		
				58	58				Dx9.463.050		
455	630	50	50	Dx9.163.063							
		50	58	Dx9.263.063							
		58	50	Dx9.363.063							
		58	58	Dx9.463.063							
710	190	400	500	58	58	40	50	581	271	64.5	Dx9.171.040
				58	63						Dx9.271.040
				63	58						Dx9.371.040
				63	63						Dx9.471.040
	290	500		58	58				Dx9.171.050		
				58	63				Dx9.271.050		
				63	58				Dx9.371.050		
				63	63				Dx9.471.050		
	420	630		58	58				Dx9.171.063		
				58	63				Dx9.271.063		
				63	58				Dx9.371.063		
				63	63				Dx9.471.063		



MDL GROUP



FRANCE

MDL
9 rue de l'Oberwald
68360 SOULTZ
✉ BP 126 - 68503 GUEBWILLER CEDEX
Tél. : +33 (0)3 89 74 24 24
Fax : +33 (0)3 89 76 49 99
E-Mail : mdl@mdl-rodís.com

PORTER-BESSON S.A.S
Zone Eurespace - 5 rue Nosières
25770 SERRE LES SAPINS
Tél. : +33 (0)3 81 58 95 00
Fax : +33 (0)3 81 58 95 09
E-Mail : porter-besson@mdl-rodís.com

GERMANY

Sitz :
Rodis GmbH
Heinrich-Krumm-Str.17
D-63073 OFFENBACH

Verkauf u.Beratung :
MDL RODIS GmbH
9 rue de l'Oberwald
F-68360 SOULTZ
Tel. : +49 (0)761 503127 11
Fax : +49 (0)761 503127 68
E-Mail : mdl-verkauf@mdl-rodís.com

BRAZIL

MDL
Av. Prink, No. 151
CEP 18120-000 MAIRINQUE, SP
Tél. : +55 11 2107 0400
Fax : +55 11 2107 0405
E-Mail : vendasp@mdl-danly.com.br

MEXICO

MDL DE MEXICO SA DE CV
Conjunto Victoria II
Acceso III No 52 Bodega 19
Zona Industrial Benito Juarez
CP 76120 QUERETARO
Tél. : +52 442 210 0020
Fax : +52 442 210 0012
E-Mail : ventas@mdlmexico.com.mx

U.S.A.

Mold & Die Components Inc.
4520 Progress Dr.
Columbus, IN 47201
Tél. : (812) 373-0021
Fax : (812) 373-0042
E-Mail : sales@mdlusa.com