

SERIE SMART

Rollers diam. 50 mm

Std smooth belt in PU
colour P320, with
slats h 20 mm pitch
40 mm

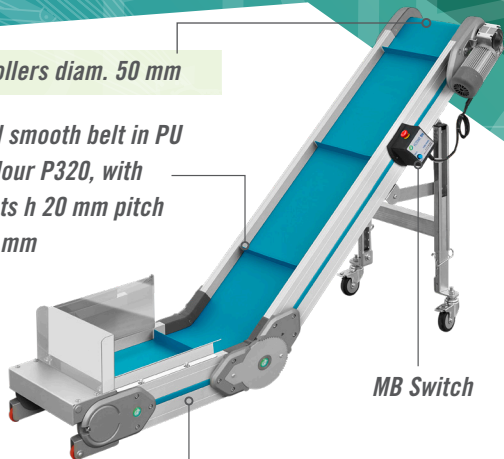

MB Switch

Structure in ALU profile h 120 mm
with integrated side edges h 35

Transmission group
0,09 kW R=1:50
Std speed 4,5 m/min

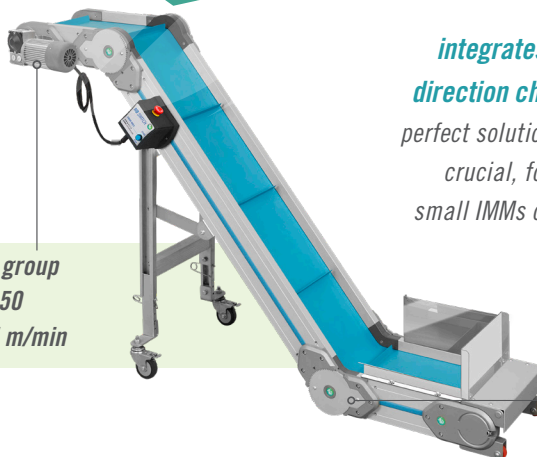

Smart Line
integrates MB's conveyors with
direction change range, offering a
perfect solution when compact size is
crucial, for example working with
small IMMs or other small machines

Adjustable direction-
change housings with
toothed aluminum insert

+ DIMENSIONS

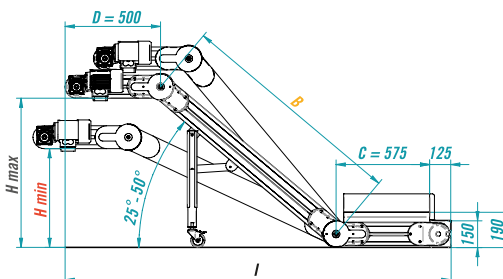
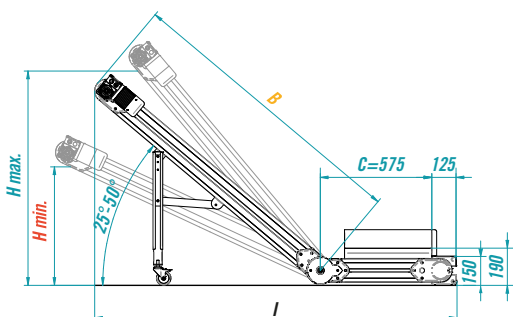

→ IMM: 40/80 ton.

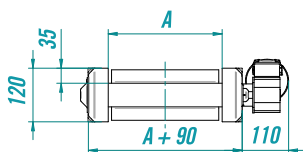

QUICK CONVEYOR SELECTION GUIDE

SMART

IMMs up to 40/80ton

Useful width up to
355mm x length max
 $B+C(+D)= 3000$ mm

Std slats h 20 mm
- h max 30 mm

Spondaflex:
NOT POSSIBLE

High-grip belt:
POSSIBLE

PC covers:
POSSIBLE without structure

N-

IMMs 80 t to 250 t

Useful width up to 540
mm x length max
 $B+C(+D)= 6000$ mm

Std slats h 35 mm
- h max 50 mm

Spondaflex h 30 mm
slats h 20 mm

Special optionals not
suitable for SMART SERIES
(PC covers with structure,
cooling systems, separators
SRS / FSRV, N-DUCK ...)

CP2021

IMMs from 250 t to 500 t, PET

Bigger size / heavy duty,
possible with special drive
roller diam 80-120mm

Slats h up to 80 mm

Spondaflex h 50 mm
slats h 30 mm

Special optionals not suitable
for SMART and N - SERIES
(internal side protections,
special belts ...)

Inclination >50° (fixed)

+ STRENGTHS:

- Lightweight structure and compact size
- Reduced consumption: 0,09 kW
- Low cost

Contact us to get a
customized quotation!