



*Every step of the way*



Die Sets & Components

**EOC**

[www.dme.net](http://www.dme.net)





**Info**

- Tolerances
- Toleranties

- Toleranzen
- Tolérances

- ① ● Tolerances total dimensions  
○ Toleranz Außenmaße  
■ Tolerantie buitenafmetingen  
□ Tolérance dimensions hors-tout

$$A/B = \begin{matrix} +0,4 \\ +0,3 \end{matrix}$$

- Tolerances thickness of plates
- Toleranz der Plattenstärke
- Tolerantie plaatdikte
- Tolérance épaisseur des plaques

$$C = \begin{matrix} +0,3 \\ +0,2 \end{matrix}$$

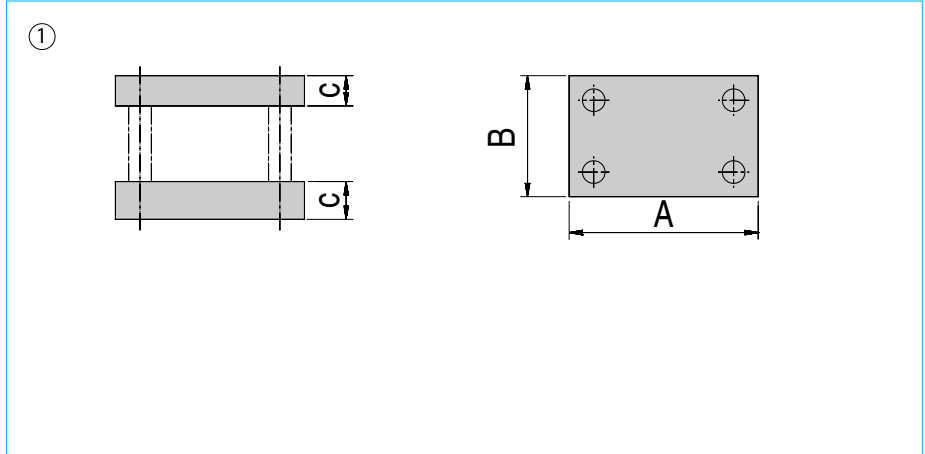

- ② ● Parallelism of opposite faces  
○ Parallelität der Flächenpaare  
■ Parallelisme van de platen  
□ Parallélisme des faces opposées

$$T_p = 0,012/100 \text{ mm}$$

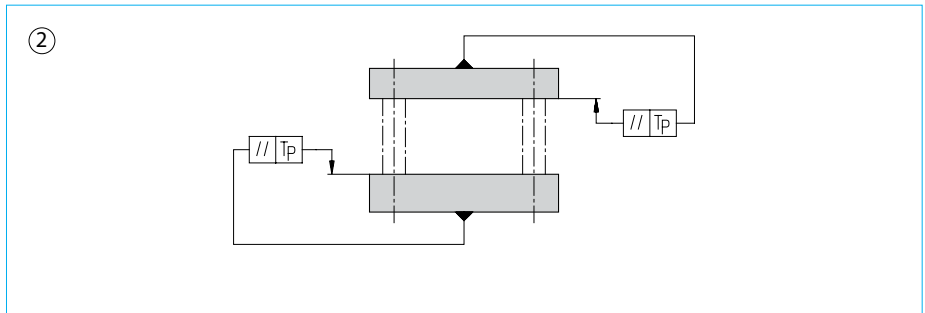

- ③ ● Parallelism of supporting surfaces  
○ Parallelität der Auflageflächen  
■ Parallelisme van de draagvlakken  
□ Parallélisme des surfaces d'appui

$$T_p = 0,015/100 \text{ mm}$$

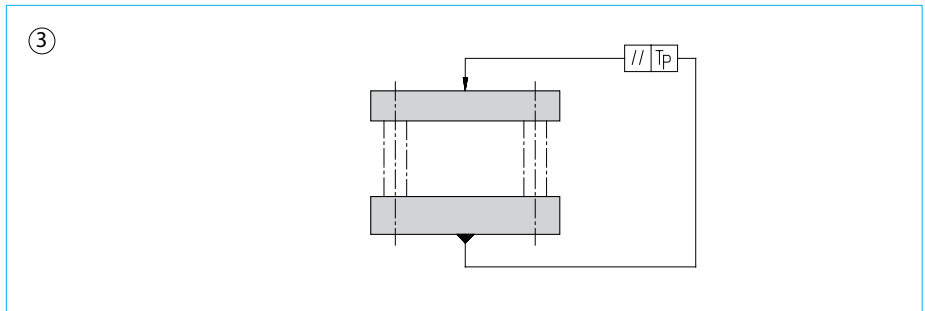

- ④ ● Tolerances system distances  
○ Toleranz Systemabstände  
■ Tolerantie van de asafstanden  
□ Tolérance d'entraxes

$$T_A = \begin{matrix} - & 100 \text{ mm} & = \pm 0,008 \text{ mm} \\ > 100 - & 180 \text{ mm} & = \pm 0,010 \text{ mm} \\ > 180 - & 350 \text{ mm} & = \pm 0,012 \text{ mm} \\ > 350 - & 500 \text{ mm} & = \pm 0,015 \text{ mm} \\ > 500 - & 710 \text{ mm} & = \pm 0,018 \text{ mm} \\ > 710 - & 1000 \text{ mm} & = \pm 0,020 \text{ mm} \end{matrix}$$

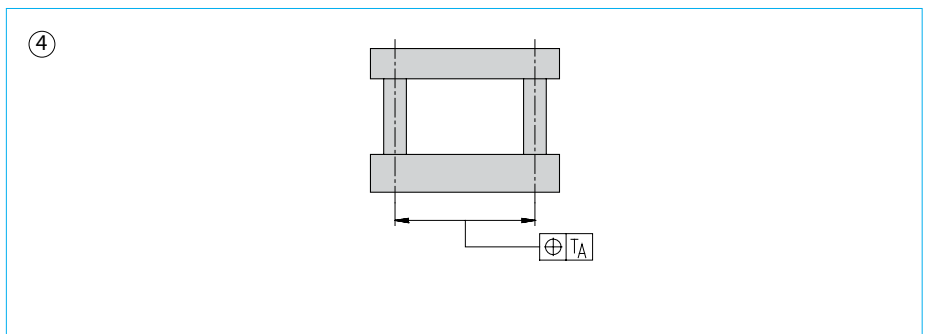

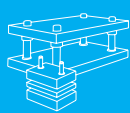

## Info

- Tolerances
- Toleranties

- Toleranzen
- Tolérances

- ⑤ ● Squareness of guide pillars
- Winkelgenauigkeit der Führungssäulen
  - Haaksheid van de geleidingszuilen
  - Equerrage des colonnes de guidage

$$T_w = 0,012/100 \text{ mm}$$

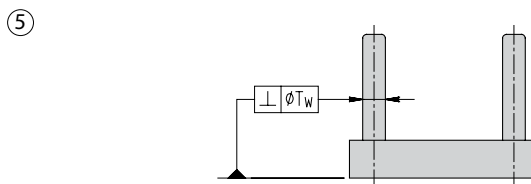

- ⑥ ● Peak-to-valley height
- Rauhtiefe
  - Oppervlakteruwheid
  - Rugosité de surface

- Faces
- Flächenpaare
- Vlakken
- Faces

$$R_z = 15$$

- Top edges
- Außenkanten
- Buitenzijden
- Champs extérieurs

$$R_z = 20$$

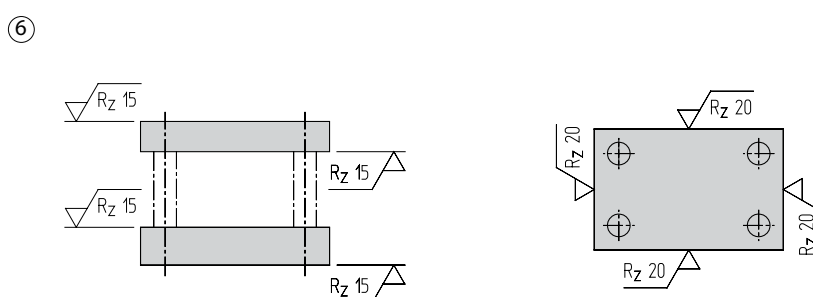

- ⑦ ● Bore tolerances
- Bohrungstoleranzen
  - Toleranties boringen
  - Tolérance d'alésage

$d_u = R7$

- Guide pillar **Wz 4020**, force fit
- Führungssäule **Wz 4020**, Preßsitz
- Geleidingszuil **Wz 4020**, perspassing
- Colonne de guidage **Wz 4020**, ajustement serré

$d_u = JS6$

- Guide pillar **Wz 4019**, sliding fit
- Führungssäule **Wz 4019**, Schiebesitz
- Geleidingszuil **Wz 4019**, lichte klempassing
- Colonne de guidage **Wz 4019**, ajustement glissant

$d_u = H6$

- Guide pillar **Wz 4000/4003**, Sliding fit
- Führungssäule **Wz 4000/4003**, Schiebesitz
- Geleidingszuil **Wz 4000/4003**, lichte klempassing
- Colonne de guidage **Wz 4000/4003**, ajustement glissant

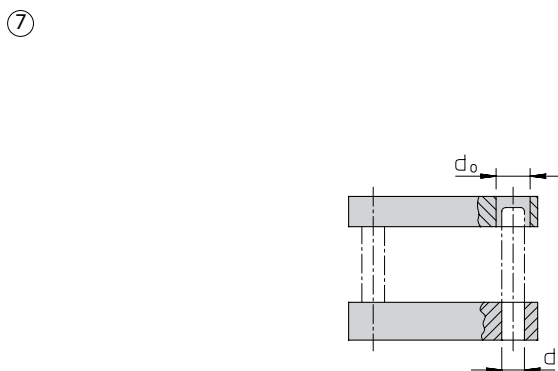

$d_o = K7$

- Guide bushing **Wz 4068**, cemented in
- Führungsbuchse **Wz 4068**, eingeklebt
- Geleidingsbus **Wz 4068**, ingelijmd
- Douille de guidage **Wz 4068**, cimentée

$d_o = H6$

- Guide bushing **Wz 40 . .**
- Führungsbuchsen **Wz 40 . .**
- Geleidingsbus **Wz 40 . .**
- Douilles de guidage **Wz 40 . .**

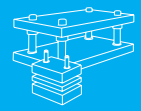

**Info**

- Order example
- Bestelvoorbeeld

- Bestellbeispiel
- Exemple de commande

<b>SG</b>	<b>/</b>	<b>2</b>	<b>/</b>	<b>A</b>	<b>/</b>	<b>1601</b>	<b>/</b>	<b>P</b>	<b>/</b>	<b>22</b>	<b>/</b>	<b>X</b>
<b>1</b>		<b>2</b>		<b>3</b>		<b>4</b>		<b>5</b>		<b>6</b>		<b>7</b>

**1** ● = Die set  
○ = Säulengestell  
■ = Stempelhuis  
□ = Bloc à colonnes

**SG**

**2** ● Die sets with 2 or 3 plates  
○ 2- oder 3-Platten-Werkzeug  
■ Stempelhuis met 2 of 3 platen  
□ Outil à 2 ou 3 plaques

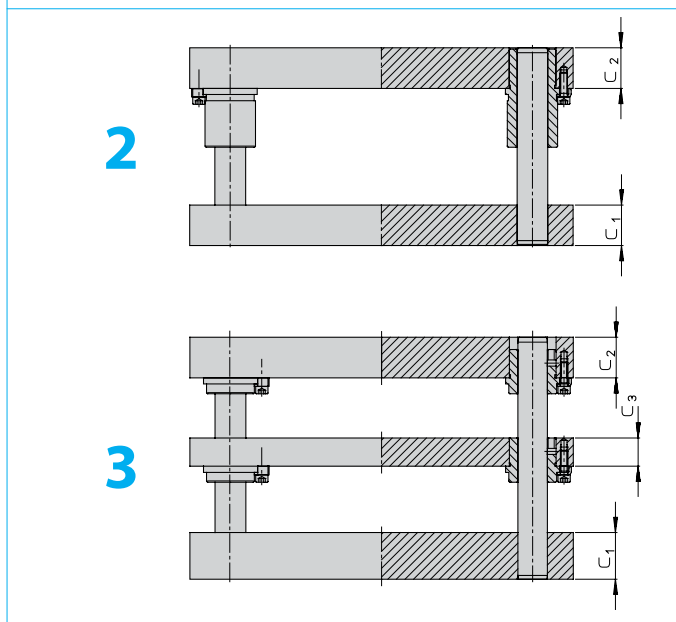

**3** ● Position of pillars and working area  
○ Säulenordnung und Arbeitsfläche  
■ Positie van de geleidingen en werkvlak  
□ Position de colonnes et surfaces de travail

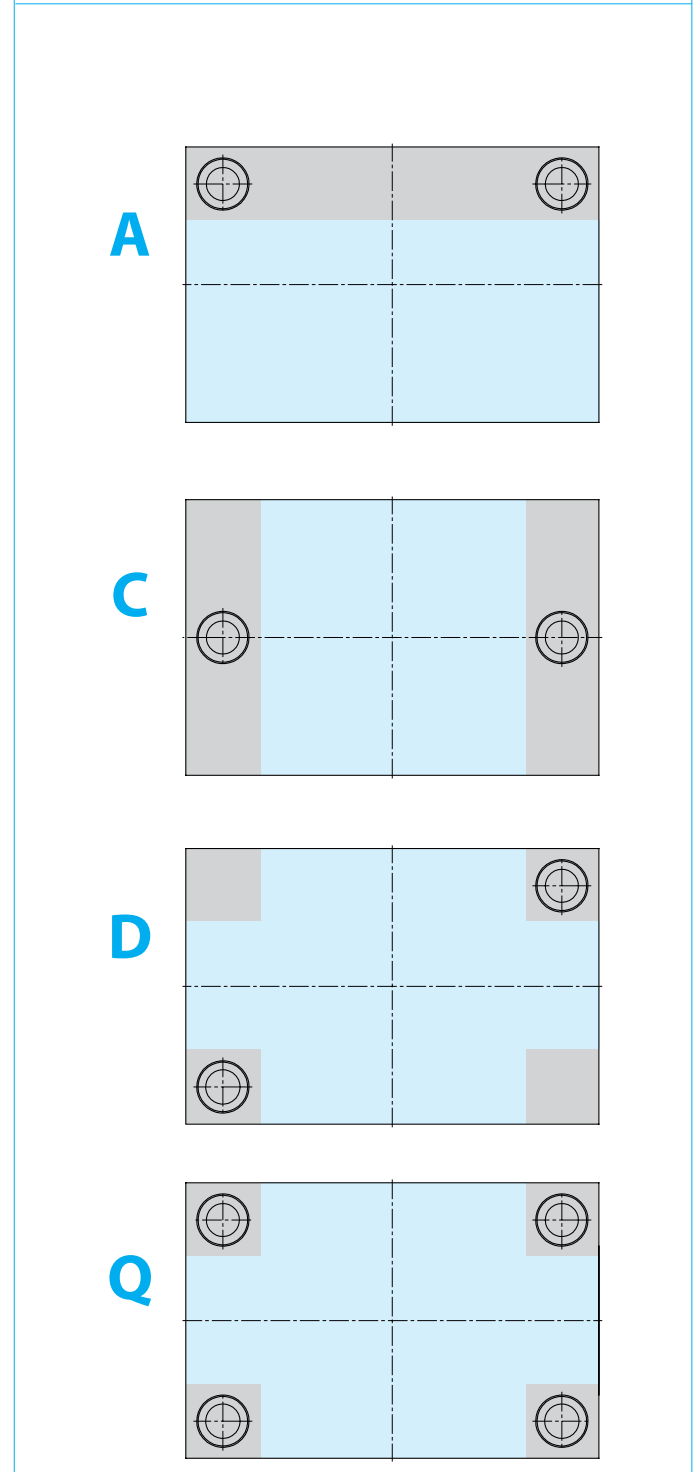

**4** ● Size ○ Größe ■ Grootte □ Taille

**1601 -** ● Die sets without stripper plate, Type A, C, D  
○ Säulengestelle ohne Stempelführungsplatte, Typ A,C,D  
■ Stempelhuis zonder tussenplaat Type A,C,D  
**1720** □ Blocs à colonnes sans plaque dévêtisseuse, Type A,C,D  
P/S **1a-1 - 1a-5**

**2601 -** ● Die sets without stripper plate, Type Q  
○ Säulengestelle ohne Stempelführungsplatte, Typ Q  
■ Stempelhuis zonder tussenplaat Type Q  
**2720** □ Blocs à colonnes sans plaque dévêtisseuse, Type Q  
P/S **1a-6 - 1a-10**

**3601 -** Die sets with stripper plate, Type A, C, D  
Säulengestelle mit Stempelführungsplatte, Typ A,C,D  
Stempelhuis met tussenplaat Type A,C,D  
**3720** Blocs à colonnes avec plaque dévêtisseuse, Type A,C,D  
P/S **1b-1 - 1b-5**

**4601 -** ● Die sets with stripper plate, Type Q  
○ Säulengestelle mit Stempelführungsplatte, Typ Q  
■ Stempelhuis met tussenplaat Type Q  
**4720** □ Blocs à colonnes avec plaque dévêtisseuse, Type Q  
P/S **1b-6 - 1b-10**

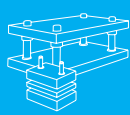

**Info**

- Order example
- Bestelvoorbeeld

- Bestellbeispiel
- Exemple de commande

<b>5</b>	<ul style="list-style-type: none"> <li>● Guide pillar ○ Führungssäule</li> <li>■ Geleidingszulen □ Colonne de guidage</li> </ul>
<b>P</b>	<p style="text-align: center;">Wz 4020 3-1</p>
<b>R</b>	<p style="text-align: center;">Wz 4019 3-2</p>
<b>S</b>	<p style="text-align: center;">Wz 4000 3-5</p>

<b>6</b>	<ul style="list-style-type: none"> <li>● Guide bushing ○ Führungsbuchse</li> <li>■ Geleidigsbussen □ Douille de guid.</li> </ul>			
<ul style="list-style-type: none"> <li>● 2 plates ○ 2 Platten ■ 2 platen □ 2 plaques</li> <li>● Sliding guides ○ Gleitführungen ■ Glijgeleidingen □ Guidages à glissement</li> </ul>	<ul style="list-style-type: none"> <li>● 3 plates ○ 3 Platten ■ 3 platen □ 3 plaques</li> <li>● Sliding guides ○ Gleitführungen ■ Glijgeleidingen □ Guidages à glissement</li> </ul>			
<p style="text-align: center;">Wz 4068 3-9</p>	<p style="text-align: center;">Wz 4040 3-13</p>	<p style="text-align: center;">Wz 4050 3-13</p>		
<b>21</b>	<b>22</b>	<b>23</b>	<p style="text-align: center;"><math>c_2 = \text{Wz 4040 } 3-13</math> <math>c_3 = \text{Wz 4030 } 3-12</math></p>	<p style="text-align: center;"><math>c_2 = \text{Wz 4039 } 3-12</math> <math>c_3 = \text{Wz 4030 } 3-12</math></p>
<b>61</b>	<b>62</b>	<p style="text-align: center;"><b>LAMINA</b> ● Sliding guides ○ Gleitführungen ■ Glijgeleidingen □ Guidages à glissement</p>		
<p style="text-align: center;">Wz 4041 3-11</p>	<p style="text-align: center;">Wz 4051 3-11</p>	<p style="text-align: center;">Wz 4055 3-11</p>	<p style="text-align: center;"><math>c_2 = \text{Wz 4041 } 3-11</math> <math>c_3 = \text{Wz 4031 } 3-10</math></p>	<p style="text-align: center;"><math>c_2 = \text{Wz 4032 } 3-10</math> <math>c_3 = \text{Wz 4031 } 3-10</math></p>
<b>31</b>	<b>32</b>	<b>33</b>	<b>71</b>	<b>72</b>
<p style="text-align: center;">● Ball guides ○ Kugelführungen ■ Kogelgeleidingen □ Guidages à billes</p>				
<p style="text-align: center;">Wz 4057 3-14</p>	<p style="text-align: center;">Wz 4058 3-15</p>	<p style="text-align: center;">Wz 4053 3-15</p>	<p style="text-align: center;"><math>c_2 = \text{Wz 4058 } 3-15</math> <math>c_3 = \text{Wz 4057 } 3-14</math></p>	<p style="text-align: center;"><math>c_2 = \text{Wz 4053 } 3-15</math> <math>c_3 = \text{Wz 4057 } 3-14</math></p>
<b>51</b>	<b>52</b>	<b>53</b>	<b>91</b>	<b>92</b>

<b>7</b>	<ul style="list-style-type: none"> <li>● Position of the fixing devices ○ Position der Haltestücke</li> <li>■ Positie van de klemstukken □ Position des dispositifs de fixation</li> </ul>
<b>X</b>	
<b>Z</b>	

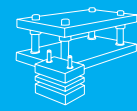

**Info**

- Order example
- Bestelvoorbeeld

- Bestellbeispiel
- Exemple de commande

● Position	● Dimensions	● Thickness			● Type of pillar in $c_1$ or $c_2$		● Type of bushing in $c_1$ or $c_2$		● Type of bushing in $c_3$		● Fixing devices
○ Position	○ Plattenmaße	○ Plattenstärke	○ Säulentyp in $c_1$ oder $c_2$			○ Buchsentyp in $c_1$ oder $c_2$		○ Buchsentyp in $c_3$		○ Haltestück	
■ Positie	■ Afmetingen	■ Plaatdiktes	■ Type van zuil in $c_1$ of $c_2$		■ Type van bus in $c_1$ of $c_2$		■ Type van bus in $c_3$		■ Positie van de klemstukken		
□ Position	□ Dimensions	□ Epaisseur	□ Type de colonne en $c_1$ ou $c_2$		□ Type de douille en $c_1$ ou $c_2$		□ Type de douille en $c_3$		□ Pos. du dispositif de fixation		
	<b>A x B</b>	$c_1$	$c_2$	$c_3$	<b>Wz....</b>	<b><math>d_1 \times l</math></b>	<b>Wz....</b>	<b><math>d \times l</math></b>	<b>Wz....</b>	<b><math>d \times l</math></b>	
<b>Q</b>	<b>877 x 545</b>	<b>88</b>	<b>78</b>	<b>48</b>	<b>4020*</b>	<b><math>50/52 \times 280</math></b>	<b>4032*</b>	<b><math>50/52 \times 75</math></b>	<b>4031*</b>	<b><math>50/52 \times 61</math></b>	<b>X</b>

\* = **Wz 4020** see / siehe / zie / voir **3-1**, **Wz 4032** see / siehe / zie / voir **3-10**, **Wz 4031** see / siehe / zie / voir **3-10**.

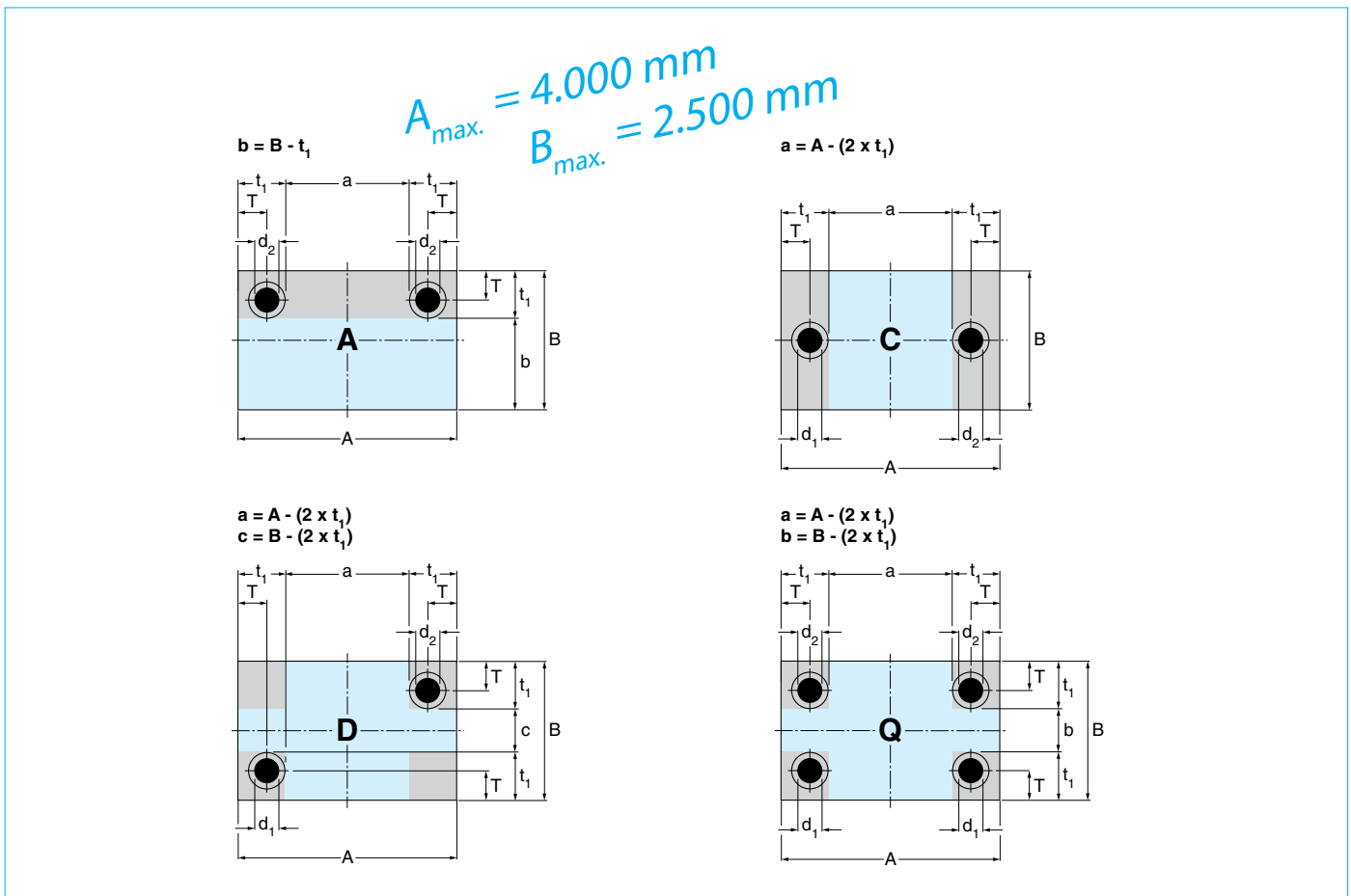

- Cylindrical guide bushing
- Zylindrische Führungsbuchsen
- Cilindrische geleidingsbussen
- Douilles de guidage cylindriques

$d_1/d_2$	T	$t_1$
18/19	23	38
24/25	27	44
30/32	35	58
40/42	43	72
50/52	50	85
63	-	-
80	-	-

- Guide bushing with collar
- Führungsbuchsen mit Bund
- Geleidingsbussen met kraag
- Douilles de guidage avec épaulement

$d_1/d_2$	T	$t_1$
18/19	30	47
24/25	35	57
30/32	42	69
40/42	47	79
50/52	55	95
63	67	113
80	78	133

- Ball guides with collar
- Kugelführungen mit Bund
- Kogelgeleidingsbussen met kraag
- Guidages à billes avec épaulement

$d_1/d_2$	T	$t_1$
18/19	33	53,0
24/25	38	63,0
30/32	46	77,0
40/42	51	87,0
50/52	59	103,0
63	80	135,0
80	93	160,5

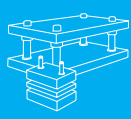

A series of horizontal dotted lines spanning the width of the page, providing a guide for writing.



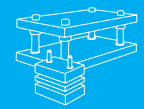

## Info

### ● Die sets without stripper plate 1601 - 1720

#### ■ Stempelhuizen zonder tussenplaat 1601 - 1720

● Guide bushing ■ Geleidingsbussen	○ Führungsbuchsen □ Douilles de guidage	
● Sliding guides ■ Stalen glijgeleidingen	○ Gleitführungen □ Guidages à glissement	
Wz 4068 3-9	Wz 4040 3-13	Wz 4050 3-13
<b>21</b>	<b>22</b>	<b>23</b>
● LAMINA-sliding guides ■ LAMINA glijgeleidingen	○ LAMINA-Gleitführungen ■ Guidages à glissement LAMINA	
Wz 4041 3-11	Wz 4051 3-11	Wz 4055 3-11
<b>31</b>	<b>32</b>	<b>33</b>
● Ball guides ■ Kogelgeleidingen	○ Kugelführungen □ Guidages à billes	
Wz 4057 3-14	Wz 4058 3-15	Wz 4053 3-15
<b>51</b>	<b>52</b>	<b>53</b>

● Guide pillars ■ Geleidingszuilen	○ Führungssäulen □ Colonnes de guidage	
Wz 4020 3-1	Wz 4019 3-2	Wz 4000 3-5
<b>P</b>	<b>R</b>	<b>S</b>

● Cylindrical guide bushing ○ Zylindrische Führungsbuchsen ■ Cilindrische geleidingsbussen □ Douilles de guidage cylindriques																								
<table border="1"> <thead> <tr> <th>d<sub>1</sub>/d<sub>2</sub></th> <th>T</th> <th>t<sub>1</sub></th> </tr> </thead> <tbody> <tr><td>18/19</td><td>23</td><td>38</td></tr> <tr><td>24/25</td><td>27</td><td>44</td></tr> <tr><td>30/32</td><td>35</td><td>58</td></tr> <tr><td>40/42</td><td>43</td><td>72</td></tr> <tr><td>50/52</td><td>50</td><td>85</td></tr> <tr><td>63</td><td>-</td><td>-</td></tr> <tr><td>80</td><td>-</td><td>-</td></tr> </tbody> </table>	d <sub>1</sub> /d <sub>2</sub>	T	t <sub>1</sub>	18/19	23	38	24/25	27	44	30/32	35	58	40/42	43	72	50/52	50	85	63	-	-	80	-	-
d <sub>1</sub> /d <sub>2</sub>	T	t <sub>1</sub>																						
18/19	23	38																						
24/25	27	44																						
30/32	35	58																						
40/42	43	72																						
50/52	50	85																						
63	-	-																						
80	-	-																						

● Guide bushing with collar ○ Führungsbuchsen mit Bund ■ Geleidingsbussen met kraag □ Douilles de guidage avec épaulement																								
<table border="1"> <thead> <tr> <th>d<sub>1</sub>/d<sub>2</sub></th> <th>T</th> <th>t<sub>1</sub></th> </tr> </thead> <tbody> <tr><td>18/19</td><td>30</td><td>47</td></tr> <tr><td>24/25</td><td>35</td><td>57</td></tr> <tr><td>30/32</td><td>42</td><td>69</td></tr> <tr><td>40/42</td><td>47</td><td>79</td></tr> <tr><td>50/52</td><td>55</td><td>95</td></tr> <tr><td>63</td><td>67</td><td>113</td></tr> <tr><td>80</td><td>78</td><td>133</td></tr> </tbody> </table>	d <sub>1</sub> /d <sub>2</sub>	T	t <sub>1</sub>	18/19	30	47	24/25	35	57	30/32	42	69	40/42	47	79	50/52	55	95	63	67	113	80	78	133
d <sub>1</sub> /d <sub>2</sub>	T	t <sub>1</sub>																						
18/19	30	47																						
24/25	35	57																						
30/32	42	69																						
40/42	47	79																						
50/52	55	95																						
63	67	113																						
80	78	133																						

● Ball guides with collar ○ Kugelführungen mit Bund ■ Kogelgeleidingsbussen met kraag □ Guidages à billes avec épaulement																								
<table border="1"> <thead> <tr> <th>d<sub>1</sub>/d<sub>2</sub></th> <th>T</th> <th>t<sub>1</sub></th> </tr> </thead> <tbody> <tr><td>18/19</td><td>33</td><td>53</td></tr> <tr><td>24/25</td><td>38</td><td>63</td></tr> <tr><td>30/32</td><td>46</td><td>77</td></tr> <tr><td>40/42</td><td>51</td><td>87</td></tr> <tr><td>50/52</td><td>59</td><td>103</td></tr> <tr><td>63</td><td>80</td><td>135</td></tr> <tr><td>80</td><td>93</td><td>160,5</td></tr> </tbody> </table>	d <sub>1</sub> /d <sub>2</sub>	T	t <sub>1</sub>	18/19	33	53	24/25	38	63	30/32	46	77	40/42	51	87	50/52	59	103	63	80	135	80	93	160,5
d <sub>1</sub> /d <sub>2</sub>	T	t <sub>1</sub>																						
18/19	33	53																						
24/25	38	63																						
30/32	46	77																						
40/42	51	87																						
50/52	59	103																						
63	80	135																						
80	93	160,5																						

### ○ Säulengestelle ohne Stempelführungsplatte 1601 - 1720 □ Blocs à colonnes sans plaque dévêtisseuse 1601 - 1720

● Position of guide elements ■ Positie van de geleidings-elementen	○ Position der Führungselemente □ Position des éléments de guidage

● Position of the fixing devices ■ Positie van de montage-klemmen	○ Position der Haltestücke □ Position des dispositifs de fixation
X	Z
	Wz 9055 3-22

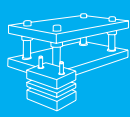

● Die sets without stripper plate 1601 - 1630

■ Stempelhuis zonder tussenplaat 1601 - 1630

○ Säulengestelle ohne Stempelführungsplatte 1601 - 1630

□ Blocs à colonnes sans plaque dévêtisseuse 1601 - 1630

Paired guides ○ Führungspaarungen ■ Geleidingscombinaties □ Guidages appariés		Dimensions ○ Abmessungen ■ Afmetingen □ Dimensions										Working areas ○ Arbeitsflächen ■ Nuttig werkvlak □ Surfaces de travail											
P/R		P/R/S		● Thickness of plates ○ Plattenstärken ■ Plaatdiktes □ Epaisseur des plaques	● Guide pillars ○ Führungssäulen ■ Geleidingszuilen □ Colonnes de guidage			21			31			22 23 32 33			51 52 53			kg			
P/R		P/R/S			Total dimensions ○ Außenmaße ■ Buitenafmetingen □ Dimensions hors-tout			P R S			P/R			P/R/S			P/R/S						
21 22 23		21 22 23		A x B	C <sub>1</sub> C <sub>2</sub> C <sub>3</sub>			d <sub>1</sub> / d <sub>2</sub>			l <sub>1</sub> l <sub>2</sub> l <sub>3</sub>			a x B			b x A			c x A			kg
31 32 33		31 32 33			18 / 19			18 / 19			80 x 121			62 x 121			74 x 156			50 x 121			
51 52 53		51 52 53		24 / 25			24 / 25			108 x 156			82 x 156			99 x 196			70 x 156			kg	

● Order help see page 1a-1 ○ Bestellhilfe siehe Seite 1a-1 ■ Bestelhulp zie pagina 1a-1 □ Aide de commande voir page 1a-1

Code	Configuration	Dimensions	Guide Pillars	Working Area	Weight
1601	●	27 22 -	18	130 100 -	7
1602	● ●	27 27 -	19	140 110 -	8
1603	● ● ●	36 27 -	19	150 110 100	9
1604	●	27 22 -	18	130 100 -	9
1605	● ●	27 27 -	19	140 110 -	10
1606	● ● ●	36 27 -	19	150 110 100	11
1607	●	27 22 -	18	130 100 -	11
1608	● ●	27 27 -	19	140 110 -	12
1609	● ● ●	36 27 -	19	150 110 100	14
1610	●	27 22 -	18	130 100 -	11
1611	● ●	27 27 -	19	140 110 -	12
1612	● ● ●	36 27 -	19	150 110 100	14
1613	●	33 27 -	24	150 110 -	16
1614	● ●	33 33 -	25	160 120 -	18
1615	● ● ●	46 36 -	25	180 130 120	23
1616	●	33 27 -	24	150 110 -	20
1617	● ●	33 33 -	25	160 120 -	22
1618	● ● ●	46 36 -	25	180 130 120	28
1619	●	33 27 -	24	150 110 -	16
1620	● ●	33 33 -	25	160 120 -	17
1621	● ● ●	46 36 -	25	180 130 120	22
1622	●	33 27 -	24	150 110 -	20
1623	● ●	33 33 -	25	160 120 -	22
1624	● ● ●	46 36 -	25	180 130 120	28
1625	●	33 27 -	24	150 110 -	25
1626	● ●	33 33 -	25	160 120 -	27
1627	● ● ●	46 36 -	25	180 130 120	35
1628	●	36 33 -	30	160 120 -	36
1629	● ●	36 36 -	32	170 130 -	39
1630	● ● ●	46 36 -	32	180 130 120	44

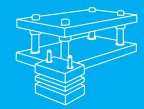

● Die sets without stripper plate 1631 - 1660  
■ Stempelhuis zonder tussenplaat 1631 - 1660

○ Säulengestelle ohne Stempelführungsplatte 1631 - 1660  
□ Blocs à colonnes sans plaque dévêtisseuse 1631 - 1660

● Paired guides ○ Führungspaarungen ■ Geleidingscombinaties □ Guidages appairés			● Dimensions ○ Abmessungen ■ Afmetingen □ Dimensions							● Working areas ○ Arbeitsflächen ■ Nuttig werkvlak □ Surfaces de travail													
P/R			P/R/S			● Thickness of plates ○ Plattenstärken ■ Plaatdiktes □ Epaisseur des plaques	● Guide pillars ○ Führungssäulen ■ Geleidingszuilen □ Colonnes de guidage			● combined with pillars ■ samengesteld met zuilen			○ kombiniert mit Säulen □ combiné avec colonnes			kg							
P/R	P/R/S	P/R/S	● Total dimensions ○ Außenmaße ■ Buitenafmetingen □ Dimensions hors-tout				d <sub>1</sub>	l <sub>1</sub>	l <sub>2</sub>	l <sub>3</sub>	a	b	c	a	b		c	a	b	c			
21	21	21	21	21	21	A	C <sub>1</sub>	C <sub>2</sub>	C <sub>3</sub>	d <sub>1</sub>	l <sub>1</sub>	l <sub>2</sub>	l <sub>3</sub>	a	b	c	a	b	c	a	b	c	kg
22	22	22												x	x	x	x	x	x	x	x	x	
31	31	31	31	31	31	B	C <sub>1</sub>	C <sub>2</sub>	C <sub>3</sub>	d <sub>2</sub>	l <sub>1</sub>	l <sub>2</sub>	l <sub>3</sub>	B	A	A	B	A	A	B	A	A	kg
22	22	22												x	x	x	x	x	x	x	x	x	
23	23	23																					
32	32	32																					
33	33	33																					
51	51	51																					
52	52	52																					
53	53	53																					

● Order help see page 1a-1 ○ Bestellhilfe siehe Seite 1a-1 ■ Bestelhulp zie pagina 1a-1 □ Aide de commande voir page 1a-1

●	→	1631	296	33	27	-	24	150	110	-	208	112	68	182	99	-	170	93	-	24
●	→	1632	x	33	33	-	/	160	120	-	x	x	x	x	x	-	x	x	-	26
●	→	1633	156	46	36	-	25	180	130	120	156	296	296	156	296		156	296		33
●		1634	296	33	27	-	24	150	110	-	208	152	108	182	139	82	170	133	70	30
●	●	1635	x	33	33	-	/	160	120	-	x	x	x	x	x	x	x	x	x	32
●	●	1636	196	46	36	-	25	180	130	120	196	296	296	196	296	296	196	296	296	42
●		1637	296	36	33	-	30	160	120	-	180	188	130	158	177	108	142	169	92	43
●	●	1638	x	36	36	-	/	170	130	-	x	x	x	x	x	x	x	x	x	46
●	●	1639	246	46	36	-	32	180	130	120	246	296	296	246	296	296	246	296	296	53
●		1640	296	36	33	-	30	160	120	-	180	238	180	158	227	158	142	219	142	52
●	●	1641	x	36	36	-	/	170	130	-	x	x	x	x	x	x	x	x	x	56
●	●	1642	296	46	36	-	32	180	130	120	296	296	296	296	296	296	296	296	296	63
●		1643	346	33	27	-	24	150	110	-	258	152	108	232	139	82	220	133	70	35
●	●	1644	x	33	33	-	/	160	120	-	x	x	x	x	x	x	x	x	x	37
●	●	1645	196	46	36	-	25	180	130	120	196	346	346	196	346	346	196	346	346	46
●		1646	346	36	33	-	30	160	120	-	230	188	130	208	177	108	192	169	92	51
●	●	1647	x	36	36	-	/	170	130	-	x	x	x	x	x	x	x	x	x	54
●	●	1648	246	46	36	-	32	180	130	120	246	346	346	246	346	346	246	346	346	61
●		1649	346	46	36	-	40	190	140	-	202	224	152	188	217	138	172	209	122	74
●	●	1650	x	46	46	-	/	200	150	-	x	x	x	x	x	x	x	x	x	83
●	●	1651	296	56	46	-	42	210	150	140	296	346	346	296	346	346	296	346	346	91
●		1652	346	46	36	-	40	190	140	-	202	274	202	188	267	188	172	259	172	86
●	●	1653	x	46	46	-	/	200	150	-	x	x	x	x	x	x	x	x	x	96
●	●	1654	346	56	46	-	42	210	150	140	346	346	346	346	346	346	346	346	346	105
●		1655	396	33	27	-	24	150	110	-	308	152	108	282	139	82	270	133	70	39
●	●	1656	x	33	33	-	/	160	120	-	x	x	x	x	x	x	x	x	x	43
●	●	1657	196	46	36	-	25	180	130	120	196	396	396	196	396	396	196	396	396	55
●		1658	396	36	33	-	30	160	120	-	280	188	130	258	177	108	242	169	92	58
●	●	1659	x	36	36	-	/	170	130	-	x	x	x	x	x	x	x	x	x	62
●	●	1660	246	46	36	-	32	180	130	120	246	396	396	246	396	396	246	396	396	69

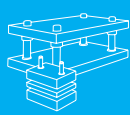

● Die sets without stripper plate 1661 - 1690  
 ■ Stempelhuis zonder tussenplaat 1661 - 1690

○ Säulengestelle ohne Stempelführungsplatte 1661 - 1690  
 □ Blocs à colonnes sans plaque dévêtisseuse 1661 - 1690

Paired guides ○ Führungspaarungen ■ Geleidingscombinaties □ Guidages appairés			● Dimensions ○ Abmessungen ■ Afmetingen □ Dimensions									● Working areas ○ Arbeitsflächen ■ Nuttig werkvlak □ Surfaces de travail								
P/R	P/R/S		● Thickness of plates ○ Plattenstärken ■ Plaatdiktes □ Epaisseur des plaques			● Guide pillars ○ Führungssäulen ■ Geleidingszuilen □ Colonnes de guidage			● combined with pillars ■ samengesteld met zuilen			○ kombiniert mit Säulen □ combiné avec colonnes			kg					
21	21	21	A	C <sub>1</sub>	C <sub>2</sub>	C <sub>3</sub>	d <sub>1</sub>	l <sub>1</sub>	l <sub>2</sub>	l <sub>3</sub>	a	b	c	a		b	c	a	b	c
21	21	21	x				/				x	x	x	x	x	x	x	x	x	x
22	22	22	x				d <sub>2</sub>				x	x	x	x	x	x	x	x	x	x
23	23	23	296								296	396	396	296	396	396	296	396	396	396
31	31	31																		
32	32	32																		
33	33	33																		
51	51	51																		
52	52	52																		
53	53	53																		

● Order help see page 1a-1 ○ Bestellhilfe siehe Seite 1a-1 ■ Bestelhulp zie pagina 1a-1 □ Aide de commande voir page 1a-1

●	●	●	1661	46	36	-	40	190	140	-	252	224	152	238	217	138	222	209	122	84
●	●	●	1662	46	46	-	42	200	150	-	x	x	x	x	x	x	x	x	x	94
●	●	●	1663	56	46	-		210	150	140										103
●			1664	46	36	-	40	190	140	-	252	274	202	238	267	188	222	259	172	98
●	●		1665	46	46	-	42	200	150	-	x	x	x	x	x	x	x	x	x	109
●	●	●	1666	56	46	-		210	150	140	346	396	396	346	396	396	346	396	396	120
●			1667	46	36	-	40	190	140	-	252	324	252	238	317	238	222	309	222	111
●	●		1668	46	46	-	42	200	150	-	x	x	x	x	x	x	x	x	x	124
●	●	●	1669	56	46	-		210	150	140	396	396	396	396	396	396	396	396	396	137
●			1670	36	33	-	30	160	120	-	380	188	130	358	177	108	342	169	92	58
●	●		1671	36	36	-	32	170	130	-	x	x	x	x	x	x	x	x	x	62
●	●	●	1672	46	36	-		180	130	120	246	496	496	246	496	496	246	496	496	69
●			1673	46	36	-	40	190	140	-	352	224	152	338	217	138	322	209	122	105
●	●		1674	46	46	-	42	200	150	-	x	x	x	x	x	x	x	x	x	116
●	●	●	1675	56	46	-		210	150	140	296	496	496	296	496	496	296	496	496	128
●			1676	46	36	-	40	190	140	-	352	274	202	338	267	188	322	259	172	122
●	●		1677	46	46	-	42	200	150	-	x	x	x	x	x	x	x	x	x	135
●	●	●	1678	56	46	-		210	150	140	346	496	496	346	496	496	346	496	496	149
●			1679	46	36	-	40	190	140	-	352	324	252	338	317	238	322	309	222	138
●	●		1680	46	46	-	42	200	150	-	x	x	x	x	x	x	x	x	x	154
●	●	●	1681	56	46	-		210	150	140	396	496	496	396	496	496	396	496	496	170
●			1682	56	46	-	50	220	160	-	326	411	326	306	401	306	290	393	290	213
●	●		1683	56	56	-	52	230	170	-	x	x	x	x	x	x	x	x	x	233
●	●	●	1684	66	56	-		240	170	160	496	496	496	496	496	496	496	496	496	252
●			1685	56	46	-	50	220	160	-	426	211	126	406	201	106	390	193	90	155
●	●		1686	56	56	-	52	230	170	-	x	x	x	x	x	x	x	x	x	169
●	●	●	1687	66	56	-		240	170	160	296	596	596	296	596	596	296	596	596	183
●			1688	56	46	-	50	220	160	-	426	261	176	406	251	156	390	243	140	180
●	●		1689	56	56	-	52	230	170	-	x	x	x	x	x	x	x	x	x	196
●	●	●	1690	66	56	-		240	170	160	346	596	596	346	596	596	346	596	596	213

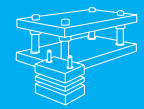

● Die sets without stripper plate 1691 - 1720  
■ Stempelhuis zonder tussenplaat 1691 - 1720

○ Säulengestelle ohne Stempelführungsplatte 1691 - 1720  
□ Blocs à colonnes sans plaque dévêtisseuse 1691 - 1720

● Paired guides ○ Führungspaarungen ■ Geleidingscombinaties □ Guidages appariés			● Dimensions ○ Abmessungen ■ Afmetingen □ Dimensions						● Working areas ○ Arbeitsflächen ■ Nuttig werkvlak □ Surfaces de travail													
P/R			P/R/S			● Thickness of plates ○ Plattenstärken ■ Plaatdiktes □ Epaisseur des plaques	● Guide pillars ○ Führungssäulen ■ Geleidingszuilen □ Colonnes de guidage			21			31			22 23 32 33			51 52 53			kg
P/R	P/R	S	A	x	B		d <sub>1</sub> / d <sub>2</sub>	l <sub>1</sub>	l <sub>2</sub>	l <sub>3</sub>	a	b	c	a	b	c	a	b	c			
21	21	21	596	x	396	50	220	160	-	426	311	226	406	301	206	390	293	190	205			
22	22	22	596	x	396	50	230	170	-	396	x	x	x	x	x	x	x	x	224			
23	23	23	596	x	396	50	240	170	160	396	596	596	396	596	596	396	596	596	242			
31	31	31	596	x	496	50	220	160	-	426	411	326	406	401	306	390	393	290	254			
32	32	32	596	x	496	50	230	170	-	496	x	x	x	x	x	x	x	x	278			
33	33	33	596	x	496	50	240	170	160	496	596	596	496	596	596	496	596	596	302			
51	51	51	696	x	346	50	220	160	-	426	511	426	406	501	406	390	493	390	305			
52	52	52	696	x	346	50	230	170	-	596	x	x	x	x	x	x	x	x	333			
53	53	53	696	x	346	50	240	170	160	596	596	596	596	596	596	596	596	596	361			

● Order help see page 1a-1 ○ Bestellhilfe siehe Seite 1a-1 ■ Bestelhulp zie pagina 1a-1 □ Aide de commande voir page 1a-1

●	●	●	1691	596	x	396	50	220	160	-	426	311	226	406	301	206	390	293	190	205
●	●	●	1692	596	x	396	50	230	170	-	396	x	x	x	x	x	x	x	x	224
●	●	●	1693	596	x	396	50	240	170	160	396	596	596	396	596	396	596	596	596	242
●	●	●	1694	596	x	496	50	220	160	-	426	411	326	406	401	306	390	393	290	254
●	●	●	1695	596	x	496	50	230	170	-	496	x	x	x	x	x	x	x	x	278
●	●	●	1696	596	x	496	50	240	170	160	496	596	596	496	596	596	496	596	596	302
●	●	●	1697	596	x	346	50	220	160	-	426	511	426	406	501	406	390	493	390	305
●	●	●	1698	596	x	346	50	230	170	-	596	x	x	x	x	x	x	x	x	333
●	●	●	1699	596	x	346	50	240	170	160	596	596	596	596	596	596	596	596	596	361
●	●	●	1700	696	x	346	50	220	160	-	526	261	176	506	251	156	490	243	140	209
●	●	●	1701	696	x	346	50	230	170	-	346	x	x	x	x	x	x	x	x	228
●	●	●	1702	696	x	346	50	240	170	160	346	696	696	346	696	696	346	696	696	247
●	●	●	1703	696	x	396	50	220	160	-	526	311	226	506	301	206	490	293	190	238
●	●	●	1704	696	x	396	50	230	170	-	396	x	x	x	x	x	x	x	x	260
●	●	●	1705	696	x	396	50	240	170	160	396	696	696	396	696	696	396	696	696	282
●	●	●	1706	696	x	496	50	220	160	-	526	411	326	506	401	306	490	393	290	296
●	●	●	1707	696	x	496	50	230	170	-	496	x	x	x	x	x	x	x	x	324
●	●	●	1708	696	x	496	50	240	170	160	496	696	696	496	696	696	496	696	696	351
●	●	●	1709	696	x	596	50	220	160	-	526	511	426	506	501	406	490	493	390	354
●	●	●	1710	696	x	596	50	230	170	-	596	x	x	x	x	x	x	x	x	388
●	●	●	1711	696	x	596	50	240	170	160	596	696	696	596	696	696	596	696	696	420
●	●	●	1712	796	x	396	50	220	160	-	626	311	226	606	301	206	590	293	190	271
●	●	●	1713	796	x	396	50	230	170	-	396	x	x	x	x	x	x	x	x	296
●	●	●	1714	796	x	396	50	240	170	160	396	796	796	396	796	796	396	796	796	321
●	●	●	1715	796	x	496	50	220	160	-	626	411	326	606	401	306	590	393	290	338
●	●	●	1716	796	x	496	50	230	170	-	496	x	x	x	x	x	x	x	x	369
●	●	●	1717	796	x	496	50	240	170	160	496	796	796	496	796	796	496	796	796	400
●	●	●	1718	796	x	596	50	220	160	-	626	511	426	606	501	406	590	493	390	404
●	●	●	1719	796	x	596	50	230	170	-	596	x	x	x	x	x	x	x	x	442
●	●	●	1720	796	x	596	50	240	170	160	596	796	796	596	796	796	596	796	796	480

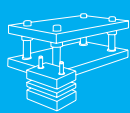

## Info

- Die sets without stripper plate 2601 - 2720
- Stempelhuizen zonder tussenplaat 2601 - 2720

● Guide bushing ■ Geleidingsbussen	○ Führungsbuchsen □ Douilles de guidage
● Sliding guides ■ Stalen glijgeleidingen	○ Gleitführungen □ Guidages à glissement

Wz 4068 3-9

**21**

Wz 4040 3-13

**22**

Wz 4050 3-13

**23**

● LAMINA sliding guides ■ LAMINA glijgeleidingen	○ LAMINA-Gleitführungen ■ Guidages à glissement LAMINA
---	---

Wz 4041 3-11

**31**

Wz 4051 3-11

**32**

Wz 4055 3-11

**33**

● Ball guides ■ Kugelgeleidingen	○ Kugelführungen □ Guidages à billes
-------------------------------------	---

Wz 4057 3-14

**51**

Wz 4058 3-15

**52**

Wz 4053 3-15

**53**

- Säulengestelle ohne Stempelführungsplatte 2601 - 2720
- Blocs à colonnes sans plaque dévêtisseuse 2601 - 2720

● Position of guide elements ■ Positie van de geleidings-elementen	○ Position der Führungselemente □ Position des éléments de guidage
---	---

● Guide pillars ■ Geleidingszuilen	○ Führungssäulen □ Colonnes de guidage
---------------------------------------	---

Wz 4020 3-1

**P**

Wz 4019 3-2

**R**

Wz 4000 3-5

**S**

● Position of the fixing devices ■ Positie van de montage-klemmen	○ Position der Haltestücke □ Position des dispositifs de fixation
--	--

**X**

**Z**

Wz 9055 3-22

● Cylindrical guide bushing ○ Zylindrische Führungsbuchsen ■ Cilindrische geleidingsbussen □ Douilles de guidage cylindriques
--

$d_1/d_2$	T	$t_1$
18/19	23	38
24/25	27	44
30/32	35	58
40/42	43	72
50/52	50	85
63	-	-
80	-	-

● Guide bushing with collar ○ Führungsbuchsen mit Bund ■ Geleidingsbussen met kraag □ Douilles de guidage avec épaulement
--

$d_1/d_2$	T	$t_1$
18/19	30	47
24/25	35	57
30/32	42	69
40/42	47	79
50/52	55	95
63	67	113
80	78	133

● Ball guides with collar ○ Kugelführungen mit Bund ■ Kugelgeleidingsbussen met kraag □ Guidages à billes avec épaulement
--

$d_1/d_2$	T	$t_1$
18/19	33	53,0
24/25	38	63,0
30/32	46	77,0
40/42	51	87,0
50/52	59	103,0
63	80	135,0
80	93	160,5

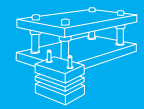

● Die sets without stripper plate 2601 - 2630  
■ Stempelhuis zonder tussenplaat 2601 - 2630

○ Säulengestelle ohne Stempelführungsplatte 2601 - 2630  
□ Blocs à colonnes sans plaque dévêtisseuse 2601 - 2630

● Paired guides ○ Führungspaarungen ■ Geleidingscombinaties □ Guidages appairés			● Dimensions ○ Abmessungen ■ Afmetingen □ Dimensions								● Working areas ○ Arbeitsflächen ■ Nuttig werkvlak □ Surfaces de travail													
P/R			P/R/S			● Thickness of plates ○ Plattenstärken ■ Plaatdiktes □ Epaisseur des plaques	● Guide pillars ○ Führungssäulen ■ Geleidingszuilen □ Colonnes de guidage			● combined with pillars ■ samengesteld met zuilen			○ kombiniert mit Säulen □ combiné avec colonnes			kg								
21	21	21	22	22	22		23	23	23	31	32	33	51	52	53									
Grootte / Tailles			Total dimensions / Außenmaße / Dimensions hors-tout			A	C <sub>1</sub>	C <sub>2</sub>	C <sub>3</sub>	d <sub>1</sub> / d <sub>2</sub>	l <sub>1</sub>	l <sub>2</sub>	l <sub>3</sub>	a	b	c	a	b	c	a	b	c		
21	21	21	22	22	22																		23	23
21	21	21	22	22	22	23	23	23	31	32	33	51	52	53	51	52	53	51	52	53	51	52	53	
51	51	51	52	52	52	53	53	53	51	52	53	51	52	53	51	52	53	51	52	53	51	52	53	

● Order help see page 1a-6 ○ Bestellhilfe siehe Seite 1a-6 ■ Bestelhulp zie pagina 1a-6 □ Aide de commande voir page 1a-6

●	○	■	□	2601	2602	2603	2604	2605	2606	2607	2608	2609	2610	2611	2612	2613	2614	2615	2616	2617	2618	2619	2620	2621	2622	2623	2624	2625	2626	2627	2628	2629	2630		
●	○	■	□	121	121	121	156	121	121	156	156	156	196	121	121	196	156	156	196	196	196	246	121	121	246	156	156	246	196	196	246	246			
●	○	■	□	27	27	27	27	27	27	27	27	27	27	27	27	27	27	27	27	27	27	27	27	27	27	27	27	27	27	27	27	27	27		
●	○	■	□	22	22	22	22	22	22	22	22	22	22	22	22	22	22	22	22	22	22	22	22	22	22	22	22	22	22	22	22	22	22		
●	○	■	□	-	-	-	-	-	-	-	-	-	-	-	-	-	-	-	-	-	-	-	-	-	-	-	-	-	-	-	-	-	-		
●	○	■	□	18	18	18	18	18	18	18	18	18	18	18	18	18	18	18	18	18	18	18	18	18	18	18	18	18	18	18	18	18	18	18	
●	○	■	□	130	140	150	130	140	150	130	140	150	130	140	150	130	140	150	130	140	150	130	140	150	130	140	150	130	140	150	130	140	150	130	
●	○	■	□	100	110	110	100	110	110	100	110	110	100	110	110	100	110	110	100	110	110	100	110	110	100	110	110	100	110	110	100	110	110	100	110
●	○	■	□	-	-	100	-	-	100	-	-	100	-	-	100	-	-	100	-	-	100	-	-	100	-	-	100	-	-	100	-	-	100	-	-
●	○	■	□	45	121	121	80	121	121	80	156	121	120	121	121	120	156	156	120	120	120	170	121	121	170	156	156	246	196	196	196	158	246	246	158
●	○	■	□	45	121	121	45	156	121	80	156	196	45	196	196	80	196	196	120	120	120	45	246	246	80	246	246	246	246	246	246	108	246	246	108
●	○	■	□	-	-	-	-	-	-	-	-	-	-	-	-	-	-	-	-	-	-	-	-	-	-	-	-	-	-	-	-	-	-	-	
●	○	■	□	27	121	121	62	121	121	62	156	121	102	121	121	102	156	196	102	102	102	152	121	121	152	156	246	246	246	132	246	246	132	246	
●	○	■	□	27	121	121	27	156	121	62	156	196	27	196	196	62	196	196	102	102	102	27	246	246	62	246	246	246	246	246	246	82	246	246	82
●	○	■	□	-	-	-	50	-	-	50	-	-	90	-	90	50	156	196	90	90	90	140	121	121	140	156	246	246	246	120	246	246	120	246	
●	○	■	□	-	-	-	-	-	-	-	-	-	-	-	-	-	-	-	-	-	-	-	-	-	-	-	-	-	-	-	-	-	-	-	
●	○	■	□	12	13	15	12	13	15	12	13	15	12	13	15	14	16	18	18	19	22	14	15	18	18	19	22	26	28	36	32	34	44		

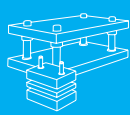

● Die sets without stripper plate 2631 - 2660  
 ■ Stempelhuis zonder tussenplaat 2631 - 2660

○ Säulengestelle ohne Stempelführungsplatte 2631 - 2660  
 □ Blocs à colonnes sans plaque dévêtisseuse 2631 - 2660

Paired guides ○ Führungspaarungen ■ Geleidingscombinaties □ Guidages appairés			● Dimensions ○ Abmessungen ■ Afmetingen □ Dimensions										● Working areas ○ Arbeitsflächen ■ Nuttig werkvlak □ Surfaces de travail								
P/R	P/R/S		● Thickness of plates ○ Plattenstärken ■ Plaatdiktes □ Epaisseur des plaques			● Guide pillars ○ Führungssäulen ■ Geleidingszuilen □ Colonnes de guidage			● combined with pillars ■ samengesteld met zuilen			○ kombiniert mit Säulen □ combiné avec colonnes			kg						
21	21	21	A	C <sub>1</sub>	C <sub>2</sub>	C <sub>3</sub>	d <sub>1</sub>	l <sub>1</sub>	l <sub>2</sub>	l <sub>3</sub>	a	b	c	a		b	c	a	b	c	
21	21	21	x				/				x	x	x	x	x	x	x	x	x	x	
22	22	22	x				d <sub>2</sub>				B	A	A	B	A	A	B	A	A		
23	23	23																			
31	31	31																			
32	32	32																			
33	33	33																			
51	51	51																			
52	52	52																			
53	53	53																			

● Order help see page 1a-6 ○ Bestellhilfe siehe Seite 1a-6 ■ Bestelhulp zie pagina 1a-6 □ Aide de commande voir page 1a-6

●	2631	33	27	-	24	150	110	-	208	68	-	182	-	-	170	-	-	25
●	2632	33	33	-	25	160	120	-	156	x	296	x	156	-	x	156	-	27
●	2633	46	36	-		180	130	120										34
●	2634	33	27	-	24	150	110	-	208	108	-	182	82	-	170	70	-	31
●	2635	33	33	-	25	160	120	-	196	x	296	x	296	-	x	x	-	33
●	2636	46	36	-		180	130	120										43
●	2637	36	33	-	30	160	120	-	180	130	-	158	108	-	142	92	-	45
●	2638	36	36	-	32	170	130	-	246	x	296	x	246	-	x	x	-	48
●	2639	46	36	-		180	130	120										54
●	2640	36	33	-	30	160	120	-	180	180	-	158	158	-	142	142	-	54
●	2641	36	36	-	32	170	130	-	296	x	296	x	296	-	x	x	-	57
●	2642	46	36	-		180	130	120										64
●	2643	33	27	-	24	150	110	-	258	108	-	232	82	-	220	70	-	36
●	2644	33	33	-	25	160	120	-	196	x	346	x	196	-	x	x	-	38
●	2645	46	36	-		180	130	120										49
●	2646	36	33	-	30	160	120	-	230	130	-	208	108	-	192	92	-	52
●	2647	36	36	-	32	170	130	-	246	x	346	x	246	-	x	x	-	56
●	2648	46	36	-		180	130	120										62
●	2649	36	33	-	30	160	120	-	230	180	-	208	158	-	192	142	-	62
●	2650	36	36	-	32	170	130	-	296	x	346	x	296	-	x	x	-	66
●	2651	46	36	-		180	130	120										74
●	2652	36	33	-	30	160	120	-	230	230	-	208	208	-	192	192	-	72
●	2653	36	36	-	32	170	130	-	346	x	346	x	346	-	x	x	-	77
●	2654	46	36	-		180	130	120										86
●	2655	33	27	-	24	150	110	-	308	108	-	282	82	-	270	70	-	40
●	2656	33	33	-	25	160	120	-	196	x	396	x	196	-	x	x	-	44
●	2657	46	36	-		180	130	120										56
●	2658	36	33	-	30	160	120	-	280	130	-	258	108	-	242	92	-	59
●	2659	36	36	-	32	170	130	-	246	x	396	x	246	-	x	x	-	63
●	2660	46	36	-		180	130	120										71



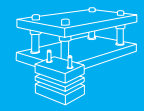

● Die sets without stripper plate 2661 - 2690  
■ Stempelhuis zonder tussenplaat 2661 - 2690

○ Säulengestelle ohne Stempelführungsplatte 2661 - 2690  
□ Blocs à colonnes sans plaque dévêtisseuse 2661 - 2690

● Paired guides ○ Führungspaarungen ■ Geleidingscombinaties □ Guidages appairés		● Dimensions ○ Abmessungen ■ Afmetingen □ Dimensions							● Working areas ○ Arbeitsflächen ■ Nuttig werkvlak □ Surfaces de travail													
P/R		P/R/S		● Grootte ■ Tailles ○ Sizes □ Größen	● Total dimensions ○ Außenmaße ■ Buitenafmetingen □ Dimensions hors-tout	● Thickness of plates ○ Plattenstärken ■ Plaatdiktes □ Epaisseur des plaques			● Guide pillars ○ Führungssäulen ■ Geleidingszuilen □ Colonnes de guidage			● combined with pillars ■ samengesteld met zuilen			○ kombiniert mit Säulen □ combiné avec colonnes			kg				
21	21	21	21			A	C <sub>1</sub>	C <sub>2</sub>	C <sub>3</sub>	d <sub>1</sub>	l <sub>1</sub>	l <sub>2</sub>	l <sub>3</sub>	a	b	c	a		b	c	a	b
21	21	21	21										x	x	x	x	x	x	x	x	x	
22	22	22	22										x	x	x	x	x	x	x	x	x	
	23	23	23																			
31	31	31	31																			
	32	32	32																			
33	33	33	33																			
51	51	51	51																			
52	52	52	52																			
	53	53	53																			

● Order help see page 1a-6 ○ Bestellhilfe siehe Seite 1a-6 ■ Bestelhulp zie pagina 1a-6 □ Aide de commande voir page 1a-6

●	→	2661	396	46	36	-	40	190	140	-	252	152	-	238	138	-	222	122	-	87
●	→	2662	x	46	46	-	/	200	150	-	x	x	-	x	x	-	x	x	-	97
●	→	2663	296	56	46	-	42	210	150	140	296	396		296	396		296	396		106
●		2664	396	46	36	-	40	190	140	-	252	202	-	238	188	-	222	172	-	101
●	●	2665	x	46	46	-	/	200	150	-	x	x	-	x	x	-	x	x	-	112
●	●	2666	346	56	46	-	42	210	150	140	346	396		346	396		346	396		123
●		2667	396	46	36	-	40	190	140	-	252	252	-	238	238	-	222	222	-	114
●	●	2668	x	46	46	-	/	200	150	-	x	x	-	x	x	-	x	x	-	127
●	●	2669	396	56	46	-	42	210	150	140	396	396		396	396		396	396		140
●		2670	496	36	33	-	30	160	120	-	380	130	-	358	108	-	342	92	-	73
●	●	2671	x	36	36	-	/	170	130	-	x	x	-	x	x	-	x	x	-	78
●	●	2672	246	46	36	-	32	180	130	120	246	496		246	496		246	496		88
●		2673	496	46	36	-	40	190	140	-	352	152	-	338	138	-	322	122	-	108
●	●	2674	x	46	46	-	/	200	150	-	x	x	-	x	x	-	x	x	-	119
●	●	2675	296	56	46	-	42	210	150	140	296	496		296	496		296	496		131
●		2676	496	46	36	-	40	190	140	-	352	202	-	338	188	-	322	172	-	125
●	●	2677	x	46	46	-	/	200	150	-	x	x	-	x	x	-	x	x	-	138
●	●	2678	346	56	46	-	42	210	150	140	346	496		346	496		346	496		152
●		2679	496	46	36	-	40	190	140	-	352	252	-	338	238	-	322	222	-	141
●	●	2680	x	46	46	-	/	200	150	-	x	x	-	x	x	-	x	x	-	157
●	●	2681	396	56	46	-	42	210	150	140	396	496		396	496		396	496		173
●		2682	496	46	36	-	40	190	140	-	352	352	-	338	338	-	322	322	-	175
●	●	2683	x	46	46	-	/	200	150	-	x	x	-	x	x	-	x	x	-	195
●	●	2684	496	56	46	-	42	210	150	140	496	496		496	496		496	496		214
●		2685	596	46	36	-	40	190	140	-	452	152	-	438	138	-	422	122	-	128
●	●	2686	x	46	46	-	/	200	150	-	x	x	-	x	x	-	x	x	-	142
●	●	2687	296	56	46	-	42	210	150	140	296	596		296	596		296	596		156
●		2688	596	46	36	-	40	190	140	-	452	202	-	438	188	-	422	172	-	148
●	●	2689	x	46	46	-	/	200	150	-	x	x	-	x	x	-	x	x	-	165
●	●	2690	346	56	46	-	42	210	150	140	346	596		346	596		346	596		181

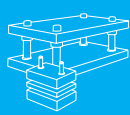

● Die sets without stripper plate 2691 - 2720  
 ■ Stempelhuis zonder tussenplaat 2691 - 2720

○ Säulengestelle ohne Stempelführungsplatte 2691 - 2720  
 □ Blocs à colonnes sans plaque dévêtisseuse 2691 - 2720

Paired guides ○ Führungspaarungen ■ Geleidingscombinaties □ Guidages appairés			● Dimensions ○ Abmessungen ■ Afmetingen □ Dimensions									● Working areas ○ Arbeitsflächen ■ Nuttig werkvlak □ Surfaces de travail								
P/R	P/R/S		● Thickness of plates ○ Plattenstärken ■ Plaatdiktes □ Epaisseur des plaques			● Guide pillars ○ Führungssäulen ■ Geleidingszuilen □ Colonnes de guidage			● combined with pillars ■ samengesteld met zuilen			○ kombiniert mit Säulen □ combiné avec colonnes			kg					
21	21	21	A	C <sub>1</sub>	C <sub>2</sub>	C <sub>3</sub>	d <sub>1</sub>	l <sub>1</sub>	l <sub>2</sub>	l <sub>3</sub>	a	b	c	a		b	c	a	b	c
21	21	21	x				/				x	x	x	x	x	x	x	x	x	x
22	22	22	x				d <sub>2</sub>				x	x	x	x	x	x	x	x	x	x
23	23	23	396								596	596	396	596	596	396	596	596	596	596
31	31	31																		
32	32	32																		
33	33	33																		
51	51	51																		
52	52	52																		
53	53	53																		

● Order help see page 1a-6 ○ Bestellhilfe siehe Seite 1a-6 ■ Bestelhulp zie pagina 1a-6 □ Aide de commande voir page 1a-6

●	●	●	2691	596	46	36	-	40	190	140	-	452	252	-	438	238	-	422	222	-	168
●	●	●	2692	x	46	46	-	/	200	150	-	x	x	-	x	x	-	x	x	-	187
●	●	●	2693	396	56	46	-	42	210	150	140	396	596		396	596		396	596		206
●	●	●	2694	596	56	46	-	50	220	160	-	426	326	-	406	306	-	390	290	-	259
●	●	●	2695	x	56	56	-	/	230	170	-	x	x	-	x	x	-	x	x	-	283
●	●	●	2696	496	66	56	-	52	240	170	160	496	596		496	596		496	596		306
●	●	●	2697	596	56	46	-	50	220	160	-	426	426	-	406	406	-	390	390	-	309
●	●	●	2698	x	56	56	-	/	230	170	-	x	x	-	x	x	-	x	x	-	337
●	●	●	2699	596	66	56	-	52	240	170	160	596	596		596	596		596	596		365
●	●	●	2700	696	46	36	-	40	190	140	-	552	202	-	538	188	-	522	172	-	172
●	●	●	2701	x	46	46	-	/	200	150	-	x	x	-	x	x	-	x	x	-	191
●	●	●	2702	346	56	46	-	42	210	150	140	346	696		346	696		346	696		210
●	●	●	2703	696	56	46	-	50	220	160	-	526	226	-	506	206	-	490	190	-	242
●	●	●	2704	x	56	56	-	/	230	170	-	x	x	-	x	x	-	x	x	-	264
●	●	●	2705	396	66	56	-	52	240	170	160	396	696		396	696		396	696		286
●	●	●	2706	696	56	46	-	50	220	160	-	526	326	-	506	306	-	490	290	-	300
●	●	●	2707	x	56	56	-	/	230	170	-	x	x	-	x	x	-	x	x	-	328
●	●	●	2708	496	66	56	-	52	240	170	160	496	696		496	696		496	696		356
●	●	●	2709	696	56	46	-	50	220	160	-	526	426	-	506	406	-	490	390	-	359
●	●	●	2710	x	56	56	-	/	230	170	-	x	x	-	x	x	-	x	x	-	392
●	●	●	2711	596	66	56	-	52	240	170	160	596	696		596	696		596	696		425
●	●	●	2712	796	56	46	-	50	220	160	-	626	226	-	606	206	-	590	190	-	276
●	●	●	2713	x	56	56	-	/	230	170	-	x	x	-	x	x	-	x	x	-	301
●	●	●	2714	396	66	56	-	52	240	170	160	396	796		396	796		396	796		326
●	●	●	2715	796	56	46	-	50	220	160	-	626	326	-	606	306	-	590	290	-	342
●	●	●	2716	x	56	56	-	/	230	170	-	x	x	-	x	x	-	x	x	-	374
●	●	●	2717	496	66	56	-	52	240	170	160	496	796		496	796		496	796		405
●	●	●	2718	796	56	46	-	50	220	160	-	626	426	-	606	406	-	590	390	-	409
●	●	●	2719	x	56	56	-	/	230	170	-	x	x	-	x	x	-	x	x	-	447
●	●	●	2720	596	66	56	-	52	240	170	160	596	796		596	796		596	796		484

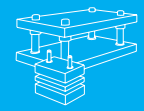

## Info

- Die sets with stripper plate 3601 - 3720
- Stempelhuizen met tussenplaat 3601 - 3720

- Säulengestelle mit Stempelführungsplatte 3601 - 3720
- Blocs à colonnes avec plaque dévêtisseuse 3601 - 3720

<ul style="list-style-type: none"> <li>● Guide bushing</li> <li>■ Geleidingsbussen</li> </ul>	<ul style="list-style-type: none"> <li>○ Führungsbuchsen</li> <li>□ Douilles de guidage</li> </ul>
<ul style="list-style-type: none"> <li>● Sliding guides</li> <li>■ Stalen glijgeleidingen</li> </ul>	<ul style="list-style-type: none"> <li>○ Gleitführungen</li> <li>□ Guidages à glissement</li> </ul>
<p>Wz 4040 3-13</p> <p>Wz 4030 3-12</p>	<p>Wz 4039 3-12</p> <p>Wz 4030 3-12</p>
<b>61</b>	<b>62</b>
<ul style="list-style-type: none"> <li>● LAMINA sliding guides</li> <li>■ LAMINA glijgeleidingen</li> </ul>	<ul style="list-style-type: none"> <li>○ LAMINA-Gleitführungen</li> <li>□ Guidages à glissement LAMINA</li> </ul>
<p>Wz 4041 3-11</p> <p>Wz 4031 3-10</p>	<p>Wz 4032 3-10</p> <p>Wz 4031 3-10</p>
<b>71</b>	<b>72</b>
<ul style="list-style-type: none"> <li>● Ball guides</li> <li>■ Kugelgeleidingen</li> </ul>	<ul style="list-style-type: none"> <li>○ Kugelführungen</li> <li>□ Guidages à billes</li> </ul>
<p>Wz 4058 3-15</p> <p>Wz 4057 3-14</p>	<p>Wz 4053 3-15</p> <p>Wz 4057 3-14</p>
<b>91</b>	<b>92</b>

<ul style="list-style-type: none"> <li>● Guide pillars</li> <li>■ Geleidingszuilen</li> </ul>	<ul style="list-style-type: none"> <li>○ Führungssäulen</li> <li>□ Colonnes de guidage</li> </ul>
<p>Wz 4020 3-1</p> <p style="text-align: center;"><b>P</b></p>	<p>Wz 4019 3-2</p> <p style="text-align: center;"><b>R</b></p>
<p>Wz 4000 3-5</p> <p style="text-align: center;"><b>S</b></p>	

<ul style="list-style-type: none"> <li>● Position of guide elements</li> <li>■ Positie van de geleidings-elementen</li> </ul>	<ul style="list-style-type: none"> <li>○ Position der Führungselemente</li> <li>□ Position des éléments de guidage</li> </ul>
<p style="text-align: center;"><b>A</b></p>	
<p style="text-align: center;"><b>C</b></p>	
<p style="text-align: center;"><b>D</b></p>	

<ul style="list-style-type: none"> <li>● Position of the fixing devices</li> <li>■ Positie van de montageklemmen</li> </ul>	<ul style="list-style-type: none"> <li>○ Position der Haltestücke</li> <li>□ Position des dispositifs de fixation</li> </ul>
<p style="text-align: center;"><b>X</b></p>	<p style="text-align: center;"><b>Z</b></p>
<p>Wz 9055 3-22</p>	

<ul style="list-style-type: none"> <li>● Cylindrical guide bushing</li> <li>○ Zylindrische Führungsbuchsen</li> <li>■ Cilindrische geleidingsbussen</li> <li>□ Douilles de guidage cylindriques</li> </ul>																								
<table border="1" style="float: right;"> <thead> <tr> <th>d<sub>1</sub>/d<sub>2</sub></th> <th>T</th> <th>t<sub>1</sub></th> </tr> </thead> <tbody> <tr><td>18/19</td><td>23</td><td>38</td></tr> <tr><td>24/25</td><td>27</td><td>44</td></tr> <tr><td>30/32</td><td>35</td><td>58</td></tr> <tr><td>40/42</td><td>43</td><td>72</td></tr> <tr><td>50/52</td><td>50</td><td>85</td></tr> <tr><td>63</td><td>-</td><td>-</td></tr> <tr><td>80</td><td>-</td><td>-</td></tr> </tbody> </table>	d <sub>1</sub> /d <sub>2</sub>	T	t <sub>1</sub>	18/19	23	38	24/25	27	44	30/32	35	58	40/42	43	72	50/52	50	85	63	-	-	80	-	-
d <sub>1</sub> /d <sub>2</sub>	T	t <sub>1</sub>																						
18/19	23	38																						
24/25	27	44																						
30/32	35	58																						
40/42	43	72																						
50/52	50	85																						
63	-	-																						
80	-	-																						

<ul style="list-style-type: none"> <li>● Guide bushing with collar</li> <li>○ Führungsbuchsen mit Bund</li> <li>■ Geleidingsbussen met kraag</li> <li>□ Douilles de guidage avec épaulement</li> </ul>																								
<table border="1" style="float: right;"> <thead> <tr> <th>d<sub>1</sub>/d<sub>2</sub></th> <th>T</th> <th>t<sub>1</sub></th> </tr> </thead> <tbody> <tr><td>18/19</td><td>30</td><td>47</td></tr> <tr><td>24/25</td><td>35</td><td>57</td></tr> <tr><td>30/32</td><td>42</td><td>69</td></tr> <tr><td>40/42</td><td>47</td><td>79</td></tr> <tr><td>50/52</td><td>55</td><td>95</td></tr> <tr><td>63</td><td>67</td><td>113</td></tr> <tr><td>80</td><td>78</td><td>133</td></tr> </tbody> </table>	d <sub>1</sub> /d <sub>2</sub>	T	t <sub>1</sub>	18/19	30	47	24/25	35	57	30/32	42	69	40/42	47	79	50/52	55	95	63	67	113	80	78	133
d <sub>1</sub> /d <sub>2</sub>	T	t <sub>1</sub>																						
18/19	30	47																						
24/25	35	57																						
30/32	42	69																						
40/42	47	79																						
50/52	55	95																						
63	67	113																						
80	78	133																						

<ul style="list-style-type: none"> <li>● Ball guides with collar</li> <li>○ Kugelführungen mit Bund</li> <li>■ Kugelgeleidingsbussen met kraag</li> <li>□ Guidages à billes avec épaulement</li> </ul>																								
<table border="1" style="float: right;"> <thead> <tr> <th>d<sub>1</sub>/d<sub>2</sub></th> <th>T</th> <th>t<sub>1</sub></th> </tr> </thead> <tbody> <tr><td>18/19</td><td>33</td><td>53,0</td></tr> <tr><td>24/25</td><td>38</td><td>63,0</td></tr> <tr><td>30/32</td><td>46</td><td>77,0</td></tr> <tr><td>40/42</td><td>51</td><td>87,0</td></tr> <tr><td>50/52</td><td>59</td><td>103,0</td></tr> <tr><td>63</td><td>80</td><td>135,0</td></tr> <tr><td>80</td><td>93</td><td>160,5</td></tr> </tbody> </table>	d <sub>1</sub> /d <sub>2</sub>	T	t <sub>1</sub>	18/19	33	53,0	24/25	38	63,0	30/32	46	77,0	40/42	51	87,0	50/52	59	103,0	63	80	135,0	80	93	160,5
d <sub>1</sub> /d <sub>2</sub>	T	t <sub>1</sub>																						
18/19	33	53,0																						
24/25	38	63,0																						
30/32	46	77,0																						
40/42	51	87,0																						
50/52	59	103,0																						
63	80	135,0																						
80	93	160,5																						

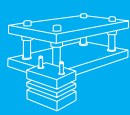

● Die sets with stripper plate 3601 - 3630  
■ Stempelhuis met tussenplaat 3601 - 3630

○ Säulengestelle mit Stempelführungsplatte 3601 - 3630  
□ Blocs à colonnes avec plaque dévêtisseuse 3601 - 3630

Paired guides ○ Führungspaarungen ■ Geleidingscombinaties □ Guidages appairés			● Dimensions ○ Abmessungen ■ Afmetingen □ Dimensions										● Working areas ○ Arbeitsflächen ■ Nuttig werkvlak □ Surfaces de travail								
P/R	P/R/S	P/R/S	● Thickness of plates ○ Plattenstärken ■ Plaatdiktes □ Epaisseur des plaques			● Guide pillars ○ Führungssäulen ■ Geleidingszuilen □ Colonnes de guidage			● combined with pillars ■ samengesteld met zuilen P/R			○ kombiniert mit Säulen □ combiné avec colonnes P/R/S			○ kombiniert mit Säulen □ combiné avec colonnes P/R/S			kg			
61	61	61	A	C <sub>1</sub>	C <sub>2</sub>	C <sub>3</sub>	d <sub>1</sub> / d <sub>2</sub>	l <sub>1</sub>	l <sub>2</sub>	l <sub>3</sub>	a	b	c	a	b	c					
61	61	61	x																		
71	71	71	x																		
71	71	71	x																		
91	91	91	x																		
91	91	91	x																		
92	92	92	x																		
92	92	92	x																		

● Order help see page 1b-1 ○ Bestellhilfe siehe Seite 1b-1 ■ Bestelhulp zie pagina 1b-1 □ Aide de commande voir page 1b-1

●	○	■	□	3601	121	27	22	18	140	120	-	-	-	-	74	-	-	68	9
●	○	■	□	3602	x	36	27	19	160	130	-	-	-	-	x	-	-	x	11
●	○	■	□	3603	121	36	36	19	170	130	120	-	-	-	121	-	-	121	12
●	○	■	□	3604	156	27	22	18	140	120	-	-	-	-	-	-	-	-	12
●	○	■	□	3605	x	36	27	19	160	130	-	-	-	62	74	-	50	68	14
●	○	■	□	3606	121	36	36	19	170	130	120	-	-	x	x	-	x	x	16
●	○	■	□	3607	156	27	22	18	140	120	-	-	-	62	74	-	50	68	15
●	○	■	□	3608	x	36	27	19	160	130	-	-	-	x	x	-	x	x	18
●	○	■	□	3609	156	36	36	19	170	130	120	-	-	156	156	-	156	156	20
●	○	■	□	3610	196	27	22	18	140	120	-	-	-	-	-	-	-	-	14
●	○	■	□	3611	x	36	27	19	160	130	-	-	-	102	74	-	90	68	17
●	○	■	□	3612	121	36	36	19	170	130	120	-	-	x	x	-	x	x	19
●	○	■	□	3613	196	33	27	24	160	130	-	-	-	82	99	-	70	93	22
●	○	■	□	3614	x	46	36	25	190	150	-	-	-	x	x	-	x	x	26
●	○	■	□	3615	156	46	46	25	200	150	140	-	-	156	196	-	156	196	31
●	○	■	□	3616	196	33	27	24	160	130	-	-	-	82	139	82	70	133	28
●	○	■	□	3617	x	46	36	25	190	150	-	-	-	x	x	-	x	x	35
●	○	■	□	3618	196	46	46	25	200	150	140	-	-	196	196	-	196	196	38
●	○	■	□	3619	246	33	27	24	160	130	-	-	-	132	64	-	120	58	22
●	○	■	□	3620	x	46	36	25	190	150	-	-	-	x	x	-	x	x	28
●	○	■	□	3621	121	46	46	25	200	150	140	-	-	121	246	-	121	246	31
●	○	■	□	3622	246	33	27	24	160	130	-	-	-	132	99	-	120	93	28
●	○	■	□	3623	x	46	36	25	190	150	-	-	-	x	x	-	x	x	35
●	○	■	□	3624	156	46	46	25	200	150	140	-	-	156	246	-	156	246	38
●	○	■	□	3625	246	33	27	24	160	130	-	-	-	132	139	82	120	133	34
●	○	■	□	3626	x	46	36	25	190	150	-	-	-	x	x	-	x	x	44
●	○	■	□	3627	196	46	46	25	200	150	140	-	-	196	246	-	196	246	48
●	○	■	□	3628	246	36	33	30	170	140	-	-	-	108	177	108	92	169	51
●	○	■	□	3629	x	46	36	32	190	150	-	-	-	x	x	-	x	x	58
●	○	■	□	3630	246	46	46	32	200	150	140	-	-	246	246	-	246	246	63

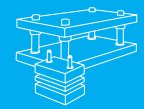

- Die sets with stripper plate 3631 - 3660
- Stempelhuis met tussenplaat 3631 - 3660

- Säulengestelle mit Stempelführungsplatte 3631 - 3660
- Blocs à colonnes avec plaque dévêtisseuse 3631 - 3660

● Paired guides ○ Führungspaarungen ■ Geleidingscombinaties □ Guidages appariés			● Dimensions ○ Abmessungen ■ Afmetingen □ Dimensions						● Working areas ○ Arbeitsflächen ■ Nuttig werkvlak □ Surfaces de travail									
P/R		P/R/S	● Grootte ■ Tailles ○ Sizes □ Größen	● Total dimensions ○ Außenmaße ■ Buitenaafmetingen □ Dimensions hors-tout	● Thickness of plates ○ Plattenstärken ■ Plaatdiktes □ Epaisseur des plaques			● Guide pillars ○ Führungssäulen ■ Geleidingszuilen □ Colonnes de guidage			● combined with pillars ■ samengesteld met zuilen □ combiné avec colonnes			○ kombiniert mit Säulen □ combiné avec colonnes			kg	
61	61	61			A	C <sub>1</sub>	C <sub>2</sub>	C <sub>3</sub>	d <sub>1</sub> / d <sub>2</sub>	l <sub>1</sub>	l <sub>2</sub>	l <sub>3</sub>	a	b	c	a		b
61	61	61	62									61	62	71	72	91	92	
71	71	71	72															
91	91	91	92															

● Order help see page 1b-1 ○ Bestellhilfe siehe Seite 1b-1 ■ Bestelhulp zie pagina 1b-1 □ Aide de commande voir page 1b-1

●	○	■	□	3631	296 x 156	33	27		24 / 25	160	130	-	-	-	182 x 156	99 x 296	-	170 x 156	93 x 296	-	33	
●	○	■	□	3632	296 x 156	46	36	22	24 / 25	190	150	-	-	-	182 x 156	99 x 296	-	170 x 156	93 x 296	-	42	
●	○	■	□	3633	296 x 156	46	46		24 / 25	200	150	140										46
●	○	■	□	3634	296 x 196	33	27		24 / 25	160	130	-			182 x 196	139 x 296	82 x 296	170 x 196	133 x 296	70 x 296		41
●	○	■	□	3635	296 x 196	46	36	22	24 / 25	190	150	-	-	-	182 x 196	139 x 296	82 x 296	170 x 196	133 x 296	70 x 296		45
●	○	■	□	3636	296 x 196	46	46		24 / 25	200	150	140										48
●	○	■	□	3637	296 x 246	36	33		30 / 32	170	140	-			158 x 246	177 x 296	108 x 296	142 x 246	169 x 296	92 x 296		60
●	○	■	□	3638	296 x 246	46	36	27	30 / 32	190	150	-	-	-	158 x 246	177 x 296	108 x 296	142 x 246	169 x 296	92 x 296		69
●	○	■	□	3639	296 x 246	46	46		30 / 32	200	150	140										75
●	○	■	□	3640	296 x 296	36	33		30 / 32	170	140	-			158 x 296	227 x 296	158 x 296	142 x 296	219 x 296	142 x 296		72
●	○	■	□	3641	296 x 296	46	36	27	30 / 32	190	150	-	-	-	158 x 296	227 x 296	158 x 296	142 x 296	219 x 296	142 x 296		83
●	○	■	□	3642	296 x 296	46	46		30 / 32	200	150	140										90
●	○	■	□	3643	346 x 196	33	27		24 / 25	160	130	-			232 x 196	139 x 346	82 x 346	220 x 196	133 x 346	70 x 346		47
●	○	■	□	3644	346 x 196	46	36	22	24 / 25	190	150	-	-	-	232 x 196	139 x 346	82 x 346	220 x 196	133 x 346	70 x 346		61
●	○	■	□	3645	346 x 196	46	46		24 / 25	200	150	140										67
●	○	■	□	3646	346 x 246	36	33		30 / 32	170	140	-			208 x 246	177 x 346	108 x 346	192 x 246	169 x 346	92 x 346		70
●	○	■	□	3647	346 x 246	46	36	27	30 / 32	190	150	-	-	-	208 x 246	177 x 346	108 x 346	192 x 246	169 x 346	92 x 346		80
●	○	■	□	3648	346 x 246	46	46		30 / 32	200	150	140										87
●	○	■	□	3649	346 x 296	46	36		40 / 42	200	160	-			188 x 296	217 x 346	138 x 346	172 x 296	209 x 346	122 x 346		101
●	○	■	□	3650	346 x 296	56	46	33	40 / 42	220	170	-	-	-	188 x 296	217 x 346	138 x 346	172 x 296	209 x 346	122 x 346		118
●	○	■	□	3651	346 x 296	56	56		40 / 42	230	170	160										126
●	○	■	□	3652	346 x 346	46	36		40 / 42	200	160	-			188 x 346	267 x 346	188 x 346	172 x 346	259 x 346	172 x 346		118
●	○	■	□	3653	346 x 346	56	46	33	40 / 42	220	170	-	-	-	188 x 346	267 x 346	188 x 346	172 x 346	259 x 346	172 x 346		137
●	○	■	□	3654	346 x 346	56	56		40 / 42	230	170	160										147
●	○	■	□	3655	396 x 196	33	27		24 / 25	160	130	-			282 x 196	139 x 396	82 x 396	270 x 196	133 x 396	70 x 396		54
●	○	■	□	3656	396 x 196	46	36	22	24 / 25	190	150	-	-	-	282 x 196	139 x 396	82 x 396	270 x 196	133 x 396	70 x 396		70
●	○	■	□	3657	396 x 196	46	46		24 / 25	200	150	140										76
●	○	■	□	3658	396 x 246	36	33		30 / 32	170	140	-			258 x 246	177 x 396	108 x 396	242 x 246	169 x 396	92 x 396		80
●	○	■	□	3659	396 x 246	46	36	27	30 / 32	190	150	-	-	-	258 x 246	177 x 396	108 x 396	242 x 246	169 x 396	92 x 396		91
●	○	■	□	3660	396 x 246	46	46		30 / 32	200	150	140										99

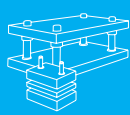

● Die sets with stripper plate 3661 - 3690  
■ Stempelhuis met tussenplaat 3661 - 3690

○ Säulengestelle mit Stempelführungsplatte 3661 - 3690  
□ Blocs à colonnes avec plaque dévêtisseuse 3661 - 3690

Paired guides ○ Führungspaarungen ■ Geleidingscombinaties □ Guidages appairés			Dimensions ○ Abmessungen ■ Afmetingen □ Dimensions										Working areas ○ Arbeitsflächen ■ Nuttig werkvlak □ Surfaces de travail								
P/R	P/R/S	P/R/S	Total dimensions ○ Außenmaße ■ Buitenaafmetingen □ Dimensions hors-tout			Thickness of plates ○ Plattenstärken ■ Plaatdiktes □ Epaisseur des plaques			Guide pillars ○ Führungssäulen ■ Geleidingszuilen □ Colonnes de guidage			combined with pillars ■ samengesteld met zuilen			kombiniert mit Säulen □ combiné avec colonnes			kg			
61	61	61	A	C <sub>1</sub>	C <sub>2</sub>	C <sub>3</sub>	d <sub>1</sub>	l <sub>1</sub>	l <sub>2</sub>	l <sub>3</sub>	a	b	c	a	b	c					
61	61	61	x				/				x	x	x	x	x	x					
71	71	71	B				d <sub>2</sub>				B	A	A	B	A	A					
91	91	91																			
	92	92																			

● Order help see page 1b-1 ○ Bestellhilfe siehe Seite 1b-1 ■ Bestelhulp zie pagina 1b-1 □ Aide de commande voir page 1b-1

●	●	●	3661	46	36		40	200	160	-				238	217	138	222	209	122	115
●	●	●	3662	56	46	33	42	220	170	-	-	-	-	296	396	396	296	396	396	134
●	●	●	3663	56	56			230	170	160										144
●	●	●	3664	46	36		40	200	160	-				238	267	188	222	259	172	134
●	●	●	3665	56	46	33	42	220	170	-	-	-	-	346	396	396	346	396	396	156
●	●	●	3666	56	56			230	170	160										167
●	●	●	3667	46	36		40	200	160	-				238	317	238	222	309	222	153
●	●	●	3668	56	46	33	42	220	170	-	-	-	-	396	396	396	396	396	396	178
●	●	●	3669	56	56			230	170	160										190
●	●	●	3670	36	33		30	170	140	-				358	177	108	342	169	92	99
●	●	●	3671	46	36	27	32	190	150	-	-	-	-	246	496	496	246	496	496	114
●	●	●	3672	46	46			200	150	140										124
●	●	●	3673	46	36		40	200	160	-				338	217	138	322	209	122	143
●	●	●	3674	56	46	33	42	220	170	-	-	-	-	296	496	496	296	496	496	167
●	●	●	3675	56	56			230	170	160										179
●	●	●	3676	46	36		40	200	160	-				338	267	188	322	259	172	167
●	●	●	3677	56	46	33	42	220	170	-	-	-	-	346	496	496	346	496	496	194
●	●	●	3678	56	56			230	170	160										208
●	●	●	3679	46	36		40	200	160	-				338	317	238	322	309	222	190
●	●	●	3680	56	46	33	42	220	170	-	-	-	-	396	496	496	396	496	496	222
●	●	●	3681	56	56			230	170	160										237
●	●	●	3682	56	46		50	230	180	-				306	401	306	290	393	290	287
●	●	●	3683	66	56	36	52	250	200	-	-	-	-	496	496	496	496	496	496	327
●	●	●	3684	66	66			260	200	180										346
●	●	●	3685	56	46		50	230	180	-				406	201	106	390	193	90	208
●	●	●	3686	66	56	36	52	250	200	-	-	-	-	296	596	596	296	596	596	237
●	●	●	3687	66	66			260	200	180										251
●	●	●	3688	56	46		50	230	180	-				406	251	156	390	243	140	242
●	●	●	3689	66	56	36	52	250	200	-	-	-	-	346	596	596	346	596	596	275
●	●	●	3690	66	66			260	200	180										292

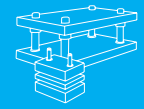

● Die sets with stripper plate 3691 - 3720  
■ Stempelhuis met tussenplaat 3691 - 3720

○ Säulengestelle mit Stempelführungsplatte 3691 - 3720  
□ Blocs à colonnes avec plaque dévêtisseuse 3691 - 3720

● Paired guides ○ Führungspaarungen ■ Geleidingscombinaties □ Guidages appareils		● Dimensions ○ Abmessungen ■ Afmetingen □ Dimensions							● Working areas ○ Arbeitsflächen ■ Nuttig werkvlak □ Surfaces de travail									
P/R	P/R/S	● Grootte □ Tailles ■ Sizes ○ Größen	● Total dimensions ○ Außenmaße ■ Buitenafmetingen □ Dimensions hors-tout	● Thickness of plates ○ Plattenstärken ■ Plaatdiktes □ Epaisseur des plaques			● Guide pillars ○ Führungssäulen ■ Geleidingszoulen □ Colonnes de guidage			● combined with pillars ■ samengesteld met zuilen			○ kombiniert mit Säulen □ combiné avec colonnes			kg		
61	61			A x B	C <sub>1</sub>	C <sub>2</sub>	C <sub>3</sub>	d <sub>1</sub> / d <sub>2</sub>	I <sub>1</sub>	I <sub>2</sub>	I <sub>3</sub>	P/R	P/R/S	P/R/S	a x B		b x A	c x A

● Order help see page 1b-1 ○ Bestellhilfe siehe Seite 1b-1 ■ Bestelhulp zie pagina 1b-1 □ Aide de commande voir page 1b-1

●		3691	596	56	46		50	230	180	-				406	301	206	390	293	190	276
●	●	3692	x 396	66	56	36	/ 52	250	200	-	-	-	-	x 396	x 596	x 596	x 396	x 596	x 596	314
●	●	3693		66	66			260	200	180										333
●		3694	596	56	46		50	230	180	-				406	401	306	390	393	290	344
●	●	3695	x 496	66	56	36	/ 52	250	200	-	-	-	-	x 496	x 596	x 596	x 496	x 596	x 596	391
●	●	3696		66	66			260	200	180										415
●		3697	596	56	46		50	230	180	-				406	501	406	390	493	390	412
●	●	3698	x 596	66	56	36	/ 52	250	200	-	-	-	-	x 596	x 596	x 596	x 596	x 596	x 596	468
●	●	3699		66	66			260	200	180										497
●		3700	696	56	46		50	230	180	-				506	251	156	490	243	140	282
●	●	3701	x 346	66	56	36	/ 52	250	200	-	-	-	-	x 346	x 696	x 696	x 346	x 696	x 696	320
●	●	3702		66	66			260	200	180										340
●		3703	696	56	46		50	230	180	-				506	301	206	490	293	190	321
●	●	3704	x 396	66	56	36	/ 52	250	200	-	-	-	-	x 396	x 696	x 696	x 396	x 696	x 696	365
●	●	3705		66	66			260	200	180										387
●		3706	696	56	46		50	230	180	-				506	401	306	490	393	290	400
●	●	3707	x 496	66	56	36	/ 52	250	200	-	-	-	-	x 496	x 696	x 696	x 496	x 696	x 696	455
●	●	3708		66	66			260	200	180										483
●		3709	696	56	46		50	230	180	-				506	501	406	490	493	390	480
●	●	3710	x 596	66	56	36	/ 52	250	200	-	-	-	-	x 596	x 696	x 696	x 596	x 696	x 696	545
●	●	3711		66	66			260	200	180										579
●		3712	796	56	46		50	230	180	-				606	301	206	590	293	190	366
●	●	3713	x 396	66	56	36	/ 52	250	200	-	-	-	-	x 396	x 796	x 796	x 396	x 796	x 796	417
●	●	3714		66	66			260	200	180										442
●		3715	796	56	46		50	230	180	-				606	401	306	590	393	290	457
●	●	3716	x 496	66	56	36	/ 52	250	200	-	-	-	-	x 496	x 796	x 796	x 496	x 796	x 796	520
●	●	3717		66	66			260	200	180										551
●		3718	796	56	46		50	230	180	-				606	501	406	590	493	390	547
●	●	3719	x 596	66	56	36	/ 52	250	200	-	-	-	-	x 596	x 796	x 796	x 596	x 796	x 796	623
●	●	3720		66	66			260	200	180										661

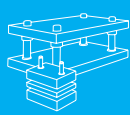

## Info

- Die sets with stripper plate 4601 - 4720
- Stempelhuizen met tussenplaat 4601 - 4720

- Säulengestelle mit Stempelführungsplatte 4601 - 4720
- Blocs à colonnes avec plaque dévêtisseuse 4601 - 4720

<ul style="list-style-type: none"> <li>● Guide bushing</li> <li>■ Geleidingsbussen</li> </ul>	<ul style="list-style-type: none"> <li>○ Führungsbuchsen</li> <li>□ Douilles de guidage</li> </ul>
<ul style="list-style-type: none"> <li>● Sliding guides</li> <li>■ Stalen glijgeleidingen</li> </ul>	<ul style="list-style-type: none"> <li>○ Gleitführungen</li> <li>□ Guidages à glissement</li> </ul>
<p>Wz 4040  3-13</p>	<p>Wz 4039  3-12</p>
<p>Wz 4030  3-12</p>	<p>Wz 4030  3-12</p>
<b>61</b>	<b>62</b>
<ul style="list-style-type: none"> <li>● LAMINA sliding guides</li> <li>■ LAMINA glijgeleidingen</li> </ul>	<ul style="list-style-type: none"> <li>○ LAMINA-Gleitführungen</li> <li>□ Guidages à glissement LAMINA</li> </ul>
<p>Wz 4041  3-11</p>	<p>Wz 4032  3-10</p>
<p>Wz 4031  3-10</p>	<p>Wz 4031  3-10</p>
<b>71</b>	<b>72</b>
<ul style="list-style-type: none"> <li>● Ball guides</li> <li>■ Kugelgeleidingen</li> </ul>	<ul style="list-style-type: none"> <li>○ Kugelführungen</li> <li>□ Guidages à billes</li> </ul>
<p>Wz 4058  3-15</p>	<p>Wz 4053  3-15</p>
<p>Wz 4057  3-14</p>	<p>Wz 4057  3-14</p>
<b>91</b>	<b>92</b>

<ul style="list-style-type: none"> <li>● Position of guide elements</li> <li>■ Positie van de geleidings-elementen</li> </ul>	<ul style="list-style-type: none"> <li>○ Position der Führungselemente</li> <li>□ Position des éléments de guidage</li> </ul>

<ul style="list-style-type: none"> <li>● Guide pillars</li> <li>■ Geleidingszuilen</li> </ul>	<ul style="list-style-type: none"> <li>○ Führungssäulen</li> <li>□ Colonnes de guidage</li> </ul>
<p>Wz 4020  3-1</p> <p style="text-align: center;"><b>P</b></p>	<p>Wz 4019  3-2</p> <p style="text-align: center;"><b>R</b></p>
<p>Wz 4000  3-5</p> <p style="text-align: center;"><b>S</b></p>	

<ul style="list-style-type: none"> <li>● Position of the fixing devices</li> <li>■ Positie van de montageklemmen</li> </ul>	<ul style="list-style-type: none"> <li>○ Position der Haltestücke</li> <li>□ Position des dispositifs de fixation</li> </ul>
<p><b>X</b></p>	<p><b>Z</b></p> <p>Wz 9055  3-22</p>

<ul style="list-style-type: none"> <li>● Cylindrical guide bushing</li> <li>○ Zylindrische Führungsbuchsen</li> <li>■ Cilindrische geleidingsbussen</li> <li>□ Douilles de guidage cylindriques</li> </ul>																								
<table border="1"> <thead> <tr> <th><math>d_1/d_2</math></th> <th>T</th> <th><math>t_1</math></th> </tr> </thead> <tbody> <tr><td>18/19</td><td>23</td><td>38</td></tr> <tr><td>24/25</td><td>27</td><td>44</td></tr> <tr><td>30/32</td><td>35</td><td>58</td></tr> <tr><td>40/42</td><td>43</td><td>72</td></tr> <tr><td>50/52</td><td>50</td><td>85</td></tr> <tr><td>63</td><td>-</td><td>-</td></tr> <tr><td>80</td><td>-</td><td>-</td></tr> </tbody> </table>	$d_1/d_2$	T	$t_1$	18/19	23	38	24/25	27	44	30/32	35	58	40/42	43	72	50/52	50	85	63	-	-	80	-	-
$d_1/d_2$	T	$t_1$																						
18/19	23	38																						
24/25	27	44																						
30/32	35	58																						
40/42	43	72																						
50/52	50	85																						
63	-	-																						
80	-	-																						

<ul style="list-style-type: none"> <li>● Guide bushing with collar</li> <li>○ Führungsbuchsen mit Bund</li> <li>■ Geleidingsbussen met kraag</li> <li>□ Douilles de guidage avec épaulement</li> </ul>																								
<table border="1"> <thead> <tr> <th><math>d_1/d_2</math></th> <th>T</th> <th><math>t_1</math></th> </tr> </thead> <tbody> <tr><td>18/19</td><td>30</td><td>47</td></tr> <tr><td>24/25</td><td>35</td><td>57</td></tr> <tr><td>30/32</td><td>42</td><td>69</td></tr> <tr><td>40/42</td><td>47</td><td>79</td></tr> <tr><td>50/52</td><td>55</td><td>95</td></tr> <tr><td>63</td><td>67</td><td>113</td></tr> <tr><td>80</td><td>78</td><td>133</td></tr> </tbody> </table>	$d_1/d_2$	T	$t_1$	18/19	30	47	24/25	35	57	30/32	42	69	40/42	47	79	50/52	55	95	63	67	113	80	78	133
$d_1/d_2$	T	$t_1$																						
18/19	30	47																						
24/25	35	57																						
30/32	42	69																						
40/42	47	79																						
50/52	55	95																						
63	67	113																						
80	78	133																						

<ul style="list-style-type: none"> <li>● Ball guides with collar</li> <li>○ Kugelführungen mit Bund</li> <li>■ Kugelgeleidingsbussen met kraag</li> <li>□ Guidages à billes avec épaulement</li> </ul>																								
<table border="1"> <thead> <tr> <th><math>d_1/d_2</math></th> <th>T</th> <th><math>t_1</math></th> </tr> </thead> <tbody> <tr><td>18/19</td><td>33</td><td>53,0</td></tr> <tr><td>24/25</td><td>38</td><td>63,0</td></tr> <tr><td>30/32</td><td>46</td><td>77,0</td></tr> <tr><td>40/42</td><td>51</td><td>87,0</td></tr> <tr><td>50/52</td><td>59</td><td>103,0</td></tr> <tr><td>63</td><td>80</td><td>135,0</td></tr> <tr><td>80</td><td>93</td><td>160,5</td></tr> </tbody> </table>	$d_1/d_2$	T	$t_1$	18/19	33	53,0	24/25	38	63,0	30/32	46	77,0	40/42	51	87,0	50/52	59	103,0	63	80	135,0	80	93	160,5
$d_1/d_2$	T	$t_1$																						
18/19	33	53,0																						
24/25	38	63,0																						
30/32	46	77,0																						
40/42	51	87,0																						
50/52	59	103,0																						
63	80	135,0																						
80	93	160,5																						



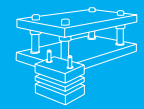

- Die sets with stripper plate 4601 - 4630
- Stempelhuis met tussenplaat 4601 - 4630

- Säulengestelle mit Stempelführungsplatte 4601 - 4630
- Blocs à colonnes avec plaque dévêtisseuse 4601 - 4630

● Paired guides ○ Führungspaarungen ■ Geleidingscombinaties □ Guidages appareils		● Dimensions ○ Abmessungen ■ Afmetingen □ Dimensions							● Working areas ○ Arbeitsflächen ■ Nuttig werkvlak □ Surfaces de travail								
P/R	P/R/S	● Grootte □ Tailles ● Sizes ○ Größen	● Total dimensions ○ Außenmaße ■ Buitenafmetingen □ Dimensions hors-tout	● Thickness of plates ○ Plattenstärken ■ Plaatdiktes □ Epaisseur des plaques			● Guide pillars ○ Führungssäulen ■ Geleidingszuilen □ Colonnes de guidage			● combined with pillars ■ samengesteld met zuilen P/R			○ kombiniert mit Säulen □ combiné avec colonnes P/R/S			kg	
61	61			61	C <sub>1</sub>	C <sub>2</sub>	C <sub>3</sub>	d <sub>1</sub> / d <sub>2</sub>	l <sub>1</sub>	l <sub>2</sub>	l <sub>3</sub>	a x B	b x A	c x A	a x B		b x A
61	61	61															
71	71	71															
		62															
		72															
91	91	91															
		92															

● Order help see page 1b-6 ○ Bestellhilfe siehe Seite 1b-6 ■ Bestelhulp zie pagina 1b-6 □ Aide de commande voir page 1b-6

●	→	4601	121	27	22		18	140	120	-				27	27			10
●	→	4602	x	36	27	17	/	160	130	-	-	-	-	x	x	-	-	12
●	→	4603	121	36	36		19	170	130	120				121	121			13
●		4604	156	27	22		18	140	120	-								12
●	→	4605	x	36	27	17	/	160	130	-	-	-	-	x	x	-	-	15
●	→	4606	121	36	36		19	170	130	120				121	156			16
●		4607	156	27	22		18	140	120	-								15
●	→	4608	x	36	27	17	/	160	130	-	-	-	-	x	x	50	50	18
●	→	4609	156	36	36		19	170	130	120				156	156	156	156	20
●		4610	196	27	22		18	140	120	-								15
●	→	4611	x	36	27	17	/	160	130	-	-	-	-	x	x	x	-	18
●	→	4612	121	36	36		19	170	130	120				121	196	121	-	20
●		4613	196	27	22		18	140	120	-								19
●	→	4614	x	36	27	17	/	160	130	-	-	-	-	x	x	90	50	23
●	→	4615	156	36	36		19	170	130	120				156	196	156	196	25
●		4616	196	27	22		18	140	120	-								23
●	→	4617	x	36	27	17	/	160	130	-	-	-	-	x	x	90	90	28
●	→	4618	196	36	36		19	170	130	120				196	196	196	196	31
●		4619	246	27	22		18	140	120	-								19
●	→	4620	x	36	27	17	/	160	130	-	-	-	-	x	x	140	-	22
●	→	4621	121	36	36		19	170	130	120				121	246	121	-	25
●		4622	246	27	22		18	140	120	-								23
●	→	4623	x	36	27	17	/	160	130	-	-	-	-	x	x	140	50	28
●	→	4624	156	36	36		19	170	130	120				156	246	156	246	31
●		4625	246	33	27		24	160	130	-								35
●	→	4626	x	46	36	22	/	190	150	-	-	-	-	x	x	120	70	45
●	→	4627	196	46	46		25	200	150	140				196	246	196	246	49
●		4628	246	33	27		24	160	130	-								43
●	→	4629	x	46	36	22	/	190	150	-	-	-	-	x	x	120	120	56
●	→	4630	246	46	46		25	200	150	140				246	246	246	246	61

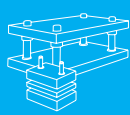

● Die sets with stripper plate 4631 - 4660  
■ Stempelhuis met tussenplaat 4631 - 4660

○ Säulengestelle mit Stempelführungsplatte 4631 - 4660  
□ Blocs à colonnes avec plaque dévêtisseuse 4631 - 4660

● Paired guides ○ Führungspaarungen ■ Geleidingscombinaties □ Guidages appairés			● Dimensions ○ Abmessungen ■ Afmetingen □ Dimensions										● Working areas ○ Arbeitsflächen ■ Nuttig werkvlak □ Surfaces de travail								
P/R	P/R/S	P/R/S	● Thickness of plates ○ Plattenstärken ■ Plaatdiktes □ Epaisseur des plaques			● Guide pillars ○ Führungssäulen ■ Geleidingszuilen □ Colonnes de guidage			● combined with pillars ■ samengesteld met zuilen P/R			○ kombiniert mit Säulen □ combiné avec colonnes P/R/S			○ kombiniert mit Säulen □ combiné avec colonnes P/R/S			kg			
61	61	61	A	C <sub>1</sub>	C <sub>2</sub>	C <sub>3</sub>	d <sub>1</sub>	l <sub>1</sub>	l <sub>2</sub>	l <sub>3</sub>	a	b	c	a	b	c					
61	61	61	x				/				x	x	x	x	x	x					
71	71	71	x				d <sub>2</sub>				B	A	A	B	A	A					
71	71	71																			
72	72	72																			
91	91	91																			
92	92	92																			

● Order help see page 1b-6 ○ Bestellhilfe siehe Seite 1b-6 ■ Bestelhulp zie pagina 1b-6 □ Aide de commande voir page 1b-6

●	●	●	4631	296	33	27		24	160	130	-				182	-	42	170	-	30	34
●	●	●	4632	x	46	36	22	25	190	150	-	-	-	-	x	-	x	x	-	x	43
●	●	●	4633	156	46	46			200	150	140				156		296	156		296	47
●	●	●	4634	296	33	27		24	160	130	-				182		82	170		70	42
●	●	●	4635	x	46	36	22	25	190	150	-	-	-	-	x	-	x	x	-	x	54
●	●	●	4636	196	46	46			200	150	140				196		296	196		296	59
●	●	●	4637	296	36	33		30	170	140	-				158		108	142		92	62
●	●	●	4638	x	46	36	27	32	190	150	-	-	-	-	x	-	x	x	-	x	71
●	●	●	4639	246	46	46			200	150	140				246		296	246		296	77
●	●	●	4640	296	36	33		30	170	140	-				158		158	142		142	73
●	●	●	4641	x	46	36	27	32	190	150	-	-	-	-	x	-	x	x	-	x	84
●	●	●	4642	296	46	46			200	150	140				296		296	296		296	91
●	●	●	4643	346	33	27		24	160	130	-				232		82	220		70	48
●	●	●	4644	x	46	36	22	25	190	150	-	-	-	-	x	-	x	x	-	x	62
●	●	●	4645	196	46	46			200	150	140				196		346	196		346	68
●	●	●	4646	346	36	33		30	170	140	-				208		108	192		92	71
●	●	●	4647	x	46	36	27	32	190	150	-	-	-	-	x	-	x	x	-	x	82
●	●	●	4648	246	46	46			200	150	140				246		346	246		346	89
●	●	●	4649	346	36	33		30	170	140	-				208		158	192		142	85
●	●	●	4650	x	46	36	27	32	190	150	-	-	-	-	x	-	x	x	-	x	97
●	●	●	4651	296	46	46			200	150	140				296		346	296		346	105
●	●	●	4652	346	36	33		30	170	140	-				208		208	192		192	99
●	●	●	4653	x	46	36	27	32	190	150	-	-	-	-	x	-	x	x	-	x	113
●	●	●	4654	346	46	46			200	150	140				346		346	346		346	123
●	●	●	4655	396	33	27		24	160	130	-				282		82	270		70	55
●	●	●	4656	x	46	36	22	25	190	150	-	-	-	-	x	-	x	x	-	x	71
●	●	●	4657	196	46	46			200	150	140				196		396	196		396	77
●	●	●	4658	396	36	33		30	170	140	-				258		108	242		92	81
●	●	●	4659	x	46	36	27	32	190	150	-	-	-	-	x	-	x	x	-	x	93
●	●	●	4660	246	46	46			200	150	140				246		396	246		396	101

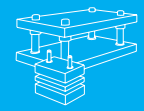

● Die sets with stripper plate 4661 - 4690  
■ Stempelhuis met tussenplaat 4661 - 4690

○ Säulengestelle mit Stempelführungsplatte 4661 - 4690  
□ Blocs à colonnes avec plaque dévêtisseuse 4661 - 4690

● Paired guides ○ Führungspaarungen ■ Geleidingscombinaties □ Guidages appairés			● Dimensions ○ Abmessungen ■ Afmetingen □ Dimensions									● Working areas ○ Arbeitsflächen ■ Nuttig werkvlak □ Surfaces de travail								
P/R	P/R/S		● Thickness of plates ○ Plattenstärken ■ Plaatdiktes □ Epaisseur des plaques			● Guide pillars ○ Führungssäulen ■ Geleidingszulen □ Colonnes de guidage			● combined with pillars ■ samengesteld met zuilen			○ kombiniert mit Säulen □ combiné avec colonnes			kg					
61	61	61	A	C <sub>1</sub>	C <sub>2</sub>	C <sub>3</sub>	d <sub>1</sub> / d <sub>2</sub>	l <sub>1</sub>	l <sub>2</sub>	l <sub>3</sub>	a	b	c	a		b	c			
61	61	61																		
61	61	62																		
71	71	71																		
71	71	72																		
91	91	91																		
91	91	92																		

● Order help see page 1b-6 ○ Bestellhilfe siehe Seite 1b-6 ■ Bestelhulp zie pagina 1b-6 □ Aide de commande voir page 1b-6

●	→	4661	396	46	36		40	200	160	-				238	138	222	122	118
●	→	4662	x	56	46	33	/	220	170	-	-	-	x	x	x	x	x	137
●	→	4663	296	56	56		42	230	170	160			296	396	296	-	396	147
●		4664	396	46	36		40	200	160	-								137
●	●	4665	x	56	46	33	/	220	170	-	-	-	x	x	x	x	x	159
●	●	4666	346	56	56		42	230	170	160			346	396	346	-	396	170
●		4667	396	46	36		40	200	160	-								156
●	●	4668	x	56	46	33	/	220	170	-	-	-	x	x	x	x	x	181
●	●	4669	396	56	56		42	230	170	160			396	396	396	-	396	194
●		4670	496	36	33		30	170	140	-								100
●	●	4671	x	46	36	27	/	190	150	-	-	-	x	x	x	x	x	115
●	●	4672	246	46	46		32	200	150	140			246	496	246	-	496	125
●		4673	496	46	36		40	200	160	-								146
●	●	4674	x	56	46	33	/	220	170	-	-	-	x	x	x	x	x	170
●	●	4675	296	56	56		42	230	170	160			296	496	296	-	496	182
●		4676	496	46	36		40	200	160	-								170
●	●	4677	x	56	46	33	/	220	170	-	-	-	x	x	x	x	x	197
●	●	4678	346	56	56		42	230	170	160			346	496	346	-	496	211
●		4679	496	46	36		40	200	160	-								193
●	●	4680	x	56	46	33	/	220	170	-	-	-	x	x	x	x	x	225
●	●	4681	396	56	56		42	230	170	160			396	496	396	-	496	240
●		4682	496	46	36		40	200	160	-								240
●	●	4683	x	56	46	33	/	220	170	-	-	-	x	x	x	x	x	279
●	●	4684	496	56	56		42	230	170	160			496	496	496	-	496	299
●		4685	596	46	36		40	200	160	-								174
●	●	4686	x	56	46	33	/	220	170	-	-	-	x	x	x	x	x	203
●	●	4687	296	56	56		42	230	170	160			296	596	296	-	596	217
●		4688	596	46	36		40	200	160	-								202
●	●	4689	x	56	46	33	/	220	170	-	-	-	x	x	x	x	x	235
●	●	4690	346	56	56		42	230	170	160			346	596	346	-	596	252

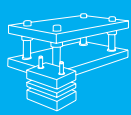

● Die sets with stripper plate 4691 - 4720  
 ■ Stempelhuis met tussenplaat 4691 - 4720

○ Säulengestelle mit Stempelführungsplatte 4691 - 4720  
 □ Blocs à colonnes avec plaque dévêtisseuse 4691 - 4720

● Paired guides ○ Führungspaarungen ■ Geleidingscombinaties □ Guidages appairés		● Dimensions ○ Abmessungen ■ Afmetingen □ Dimensions				● Working areas ○ Arbeitsflächen ■ Nuttig werkvlak □ Surfaces de travail												
P/R	P/R/S	● Grootte ■ Tailles ● Sizes ○ Größen	● Total dimensions ○ Außenmaße ■ Buitenaftmetingen □ Dimensions hors-tout		● Thickness of plates ○ Plattenstärken ■ Plaatdiktes □ Epaisseur des plaques			● Guide pillars ○ Führungssäulen ■ Geleidingszuilen □ Colonnes de guidage			● combined with pillars ■ samengesteld met zuilen P/R			○ kombiniert mit Säulen □ combiné avec colonnes P/R/S			kg	
61	61		61	A	C <sub>1</sub>	C <sub>2</sub>	C <sub>3</sub>	d <sub>1</sub>	l <sub>1</sub>	l <sub>2</sub>	l <sub>3</sub>	a	b	c	a	b		c
71	71		71	x				/				x	x	x	x	x		x
91	91		91	B				d <sub>2</sub>				B	A	A	B	A		A

● Order help see page 1b-6 ○ Bestellhilfe siehe Seite 1b-6 ■ Bestelhulp zie pagina 1b-6 □ Aide de commande voir page 1b-6

●	4691	596	46	36	40	200	160	-				438	-	238	422	-	222	230
●	4692	x	56	46	33	42	220	170	-	-	-	x	-	x	x	-	x	268
●	4693	396	56	56			230	170	160			396	-	596	396	-	596	287
●	4694	596	56	46	50	230	180	-				406	-	306	390	-	290	348
●	4695	x	66	56	36	52	250	200	-	-	-	x	-	x	x	-	x	395
●	4696	496	66	66			260	200	180			496	-	596	496	-	596	419
●	4697	596	56	46	50	230	180	-				406	-	406	390	-	390	416
●	4698	x	66	56	36	52	250	200	-	-	-	x	-	x	x	-	x	473
●	4699	596	66	66			260	200	180			596	-	596	596	-	596	501
●	4700	696	46	36	40	200	160	-				538	-	188	522	-	172	225
●	4701	x	56	46	33	42	220	170	-	-	-	x	-	x	x	-	x	274
●	4702	346	56	56			230	170	160			346	-	696	346	-	696	293
●	4703	696	56	46	50	230	180	-				506	-	206	490	-	190	326
●	4704	x	66	56	36	52	250	200	-	-	-	x	-	x	x	-	x	370
●	4705	396	66	66			260	200	180			396	-	696	396	-	696	392
●	4706	696	56	46	50	230	180	-				506	-	306	490	-	290	405
●	4707	x	66	56	36	52	250	200	-	-	-	x	-	x	x	-	x	460
●	4708	496	66	66			260	200	180			496	-	696	496	-	696	487
●	4709	696	56	46	50	230	180	-				506	-	406	490	-	390	484
●	4710	x	66	56	36	52	250	200	-	-	-	x	-	x	x	-	x	550
●	4711	596	66	66			260	200	180			596	-	696	596	-	696	583
●	4712	796	56	46	50	230	180	-				606	-	206	590	-	190	371
●	4713	x	66	56	36	52	250	200	-	-	-	x	-	x	x	-	x	421
●	4714	396	66	66			260	200	180			396	-	796	396	-	796	447
●	4715	796	56	46	50	230	180	-				606	-	306	590	-	290	461
●	4716	x	66	56	36	52	250	200	-	-	-	x	-	x	x	-	x	524
●	4717	496	66	66			260	200	180			496	-	796	496	-	796	556
●	4718	796	56	46	50	230	180	-				606	-	406	590	-	390	552
●	4719	x	66	56	36	52	250	200	-	-	-	x	-	x	x	-	x	627
●	4720	596	66	66			260	200	180			596	-	796	596	-	796	665