





VERTICAL SERIES

The clamping and control levers move in the same direction. When clamping is obtained, the control lever is in the vertical position. The light version of the series presented in this catalogue has a retaining force between 75 and 875 daN, while the heavy-duty version has a retaining force between 1000 and 3000 daN. The heavy-duty version is used when highly intense resistant forces are used, for example when closing jigs for foams, polyurethanes, etc. The clamps of this series are built to be easily disassembled for reworking of the individual elements depending on the requirements of use.

PERFORMANCE

FOR THE LIGHT SERIES: Components in case-hardening sheet steel. Hardened and tempered supporting pivots. Supporting bushes (for sizes from 130 daN and over) hardened by cementation and ground. The clamping lever is shorn and reinforced in the points of maximum stress. In the closing movement, it is guided laterally to ensure greater stability against possible transverse stresses. Finishing of the series: galvanized.

FOR THE HEAVY-DUTY SERIES: The pivots and supporting bushes are made of tempered and ground steel. The other parts are made of weldable steel. Finishing of the series: phosphated.

The red handles are made of polyurethane and are resistant to oils, solvents and other chemical agents.

In order to prevent accidental openings, caused by vibrations, some tools of this series are provided with a device called, "safety device", suitable for maintaining the clamp in a closed position. This device is also able to lock the tool in open position (Pat.Pend.)

VERTICAL SERIES WITH FOLDED BASE

Some sizes of this series are also produced in stainless steel and are shown below in red.

Material:

Galvanized steel or **AISI 304 stainless steel**

Riveted pivots:

Galvanized steel or **AISI 304 stainless steel**

Supporting bushes:

Hardened and ground steel (for sizes ≥ 130)

Handles:

Red polyurethane; resistant to oils, grease and other chemical agents.

Performance:

Form A and **form AX** with open clamping lever and two flanged washers.

Form E and **form EX** with full clamping lever and bolt retainers to be welded in the desired position and angle.

Spindles:

To be ordered separately (see Accessories on page 87).

Characteristics and applications:

During the closing, the clamping lever is guided laterally to ensure greater stability against possible transverse stresses.

These tools are designed to prevent the operator's fingers from being crushed by the levers when opening.

A special grease is placed between two contacting surfaces during assembly.

This pneumatic actuated series is found on page 75.

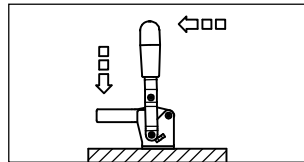

FORM A

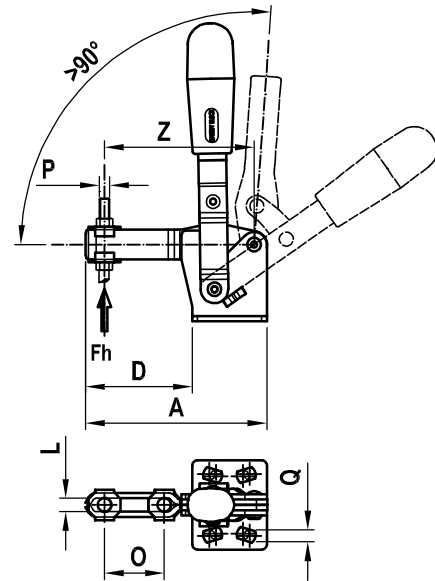

FORM E

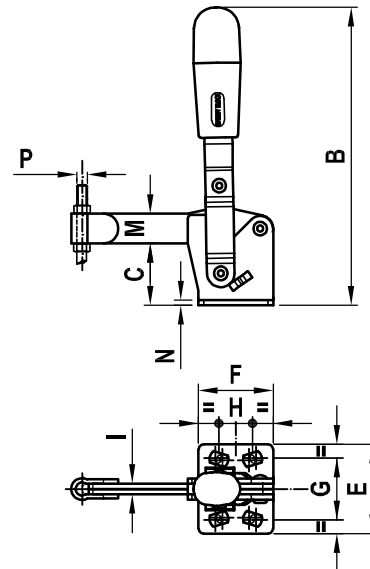

Code	Description	Stainless steel Code	Description	A	B	C	D	E	F	G	H	I	L	M	N	O	P	Q	Z	Fh (daN)	gr.
AA520	75/A	AS095	75/AX	66,5	98	20,5	37,5	34	29	24	15÷16		5,2	11	2	20	M5	4,5	56	75	98
AA524	75/E	AS105	75/EX	67	98	20,5	38	34	29	24	15÷16	4		11	2		M5	4,5		75	100
AA530	130/A	AS150	130/AX	85	142	28	50	42	35	27÷29	12,5÷19		6,2	16	2,5	28	M6	5,6	71	105	230
AA534	130/E	AS160	130/EX	86	142	28	51	42	35	27÷29	12,5÷19	5		16	2,5		M6	5,6		105	235
AA540	230/A	AS180	230/AX	110,5	168	33,5	67,5	45	43	32	18÷21		8,5	18	3	40	M8	6,7	94	200	380
AA544	230/E	AS190	230/EX	112	168	33,5	69	45	43	32	18÷21	6		18	3		M8	6,7		200	390
AA550	330/A			129	195	43	79	65	50	45÷46	29÷32		10,5	22	3,5	43	M10	8,5	108	240	604
AA554	330/E			130,5	195	43	80,5	65	50	45÷46	29÷32	7		22	3,5		M10	8,5		240	604
AA560	430/A			164	247	55,5	106	65	58	45	32		12,5	26	4	64	M12	8,5	138	280	1100
AA564	430/E			166	247	55,5	108	65	58	45	32	10		26	4		M12	8,5		280	1100
AA570	530/A			223	303	84,5	143	95	80	70	50÷51		12,5	32	7	90	M12	12,5	195	450	2110
AA574	530/E			225	303	84,5	145	95	80	70	50÷51	10		32	7		M12	12,5	450	450	2110

FORM B

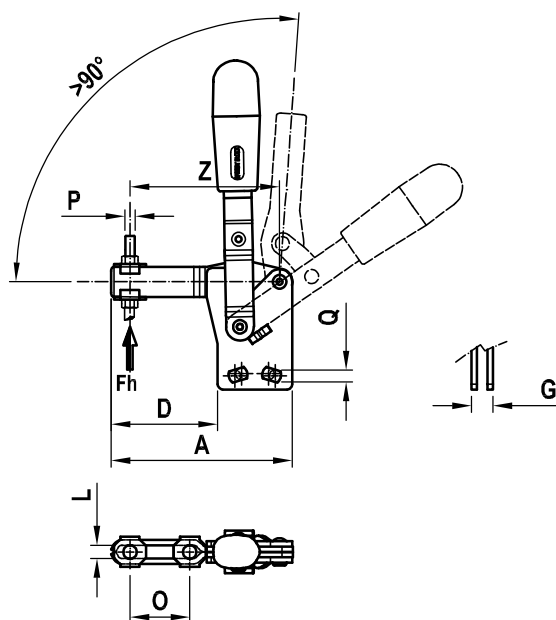

VERTICAL SERIES WITH STRAIGHT BASE

Some sizes of this series are also produced in stainless steel and are shown below in red.

Material:

Galvanized steel or **AISI 304 stainless steel**

Riveted pivots:

Galvanized steel or **AISI 304 stainless steel**

Supporting bushes:

Hardened and ground steel (for sizes ≥ 130)

Handles:

Red polyurethane resistant to oils, grease and other chemical agents.

Performance:

Form B and **form BX** with open clamping lever and two flanged washers.

Form F and **form FX** with full clamping lever and bolt retainers to be welded in the desired position and angle.

Spindles:

To be ordered separately (see Accessories on page 87).

Features and applications:

During the closing, the clamping lever is guided laterally to ensure greater stability against possible transverse stresses.

These tools are designed to prevent the operator's fingers from being crushed by the levers when opening.

A special grease is placed between two contacting surfaces during assembly.

FORM F

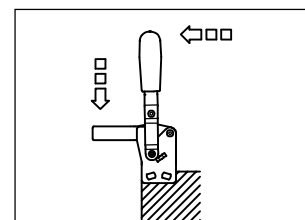
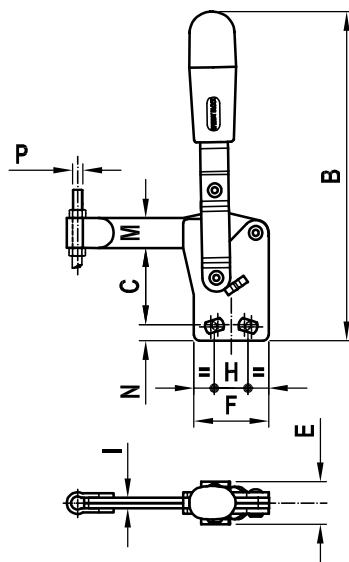

Code	Description	Stainless steel Code	Description	A	B	C	D	E	F	G	H	I	L	M	N	O	P	Q	Z	Fh (daN)	gr.
AA522	75/B	AS100	75/BX	66,5	109,5	27	37,5	16	29	8	15÷16		5,2	11	5	20	M5	4,5	56	75	98
AA526	75/F	AS110	75/FX	67	109,5	27	38	16	29	8	15÷16	4		11	5		M5	4,5		75	100
AA532	130/B	AS155	130/BX	85	156	35	50	20	35	10	12,5÷19		6,2	16	6,5	28	M6	5,6	71	105	230
AA536	130/F	AS165	130/FX	86	156	35	51	20	35	10	12,5÷19	5		16	6,5		M6	5,6		105	235
AA542	230/B	AS185	230/BX	110,5	183	41,5	67,5	23	43	12	18÷21		8,5	18	6,5	40	M8	6,7	94	200	380
AA546	230/F	AS195	230/FX	112	183	41,5	69	23	43	12	18÷21	6		18	6,5		M8	6,7		200	390
AA552	330/B			129	218	56,5	79	25	50	14	29÷32		10,5	22	9,5	43	M10	8,5	108	240	620
AA556	330/F			130,5	218	56,5	80,5	25	50	14	29÷32	7		22	9,5		M10	8,5		240	620
AA562	430/B			164	267,5	67,5	106	34	58	18	32		12,5	26	10	64	M12	8,5	138	280	1110
AA566	430/F			166	267,5	67,5	108	34	58	18	32	10		26	10		M12	8,5		280	1110
AA572	530/B			223	337	105	146	34	77	18	50÷51		12,5	32	12,5	90	M12	12,5	195	450	1920
AA576	530/F			225	337	105	148	34	77	18	50÷51	10		32	12,5		M12	12,5		450	1920

VERTICAL SERIES WITH FOLDED BASE AND ANTI-RELEASE LEVER

Some sizes of this series are also produced in stainless steel and are shown below in red.

Material:

Galvanized steel or **AISI 304 stainless steel**

Riveted pivots:

Galvanized steel or **AISI 304 stainless steel**

Supporting bushes:

Hardened and ground steel.

Handles:

Red polyurethane resistant to oils, grease and other chemical agents.

Performance:

Form AL and **form ALX** with open clamping lever and two flanged washers.

Form EL and **form ELX** with full clamping lever and bolt retainers to be welded in the desired position and angle.

Spindles:

To be ordered separately (see Accessories on page 87).

Features and applications:

The main feature of this series is the special anti-release lever with the purpose of avoiding any accidental openings caused by vibrations; and to block the tool in the open position; these tools are designed to prevent the operator's fingers from being crushed by the levers when opening. During the closing, the clamping lever is guided laterally to ensure greater stability against possible transverse stresses. A special grease is placed between two contacting surfaces during assembly.

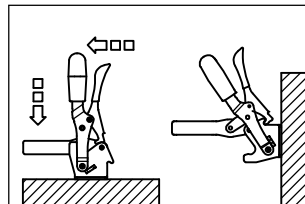

FORM AL



PATENTED

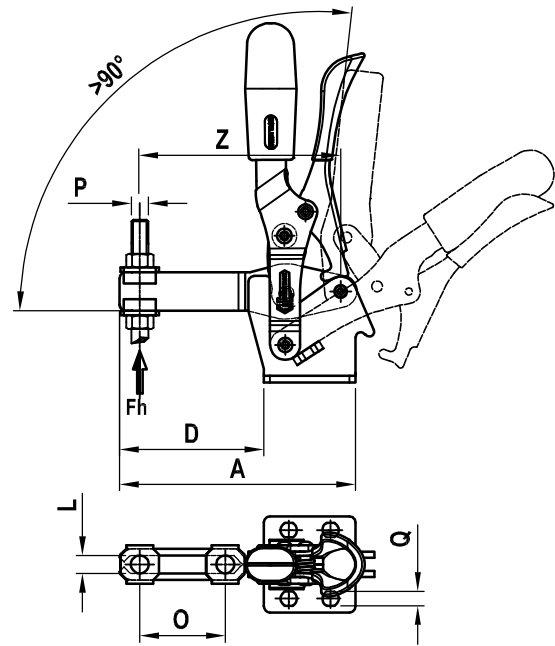

FORM EL



PATENTED

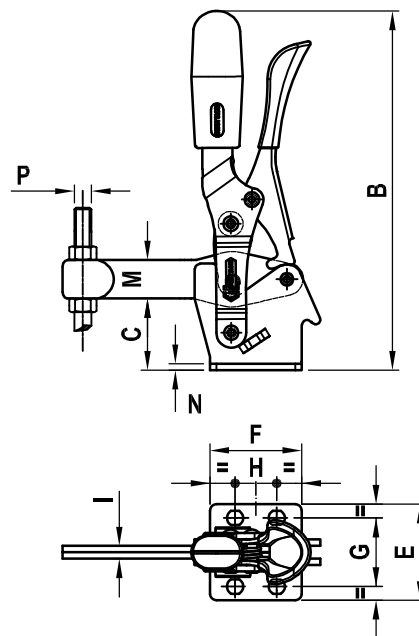

Code	Description	Stainless steel Code	Description	A	B	C	D	E	F	G	H	I	L	M	N	O	P	Q	Z	Fh (daN)	gr.
AA582	130/AL	AS200	130/ALX	85	142	28	50	42	35	27÷29	12,5÷19		6,2	16	2,5	28	M6	5,6	71	105	275
AA586	130/EL	AS204	130/ELX	86	142	28	51	42	35	27÷29	12,5÷19	5		16	2,5		M6	5,6		105	280
AA590	230/AL	AS210	230/ALX	110,5	168	33,5	67,5	45	43	32	18÷21		8,5	18	3	40	M8	6,7	94	200	380
AA594	230/EL	AS214	230/ELX	112	168	33,5	69	45	43	32	18÷21	6		18	3		M8	6,7		200	390

FORM BL



PATENTED

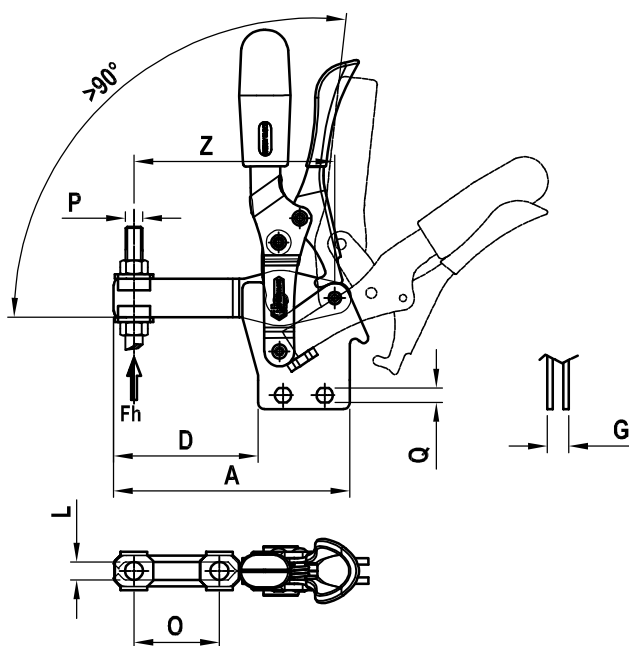

FORM FL



PATENTED

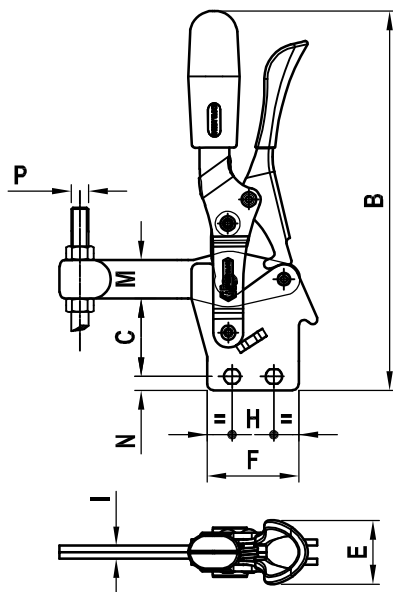

VERTICAL SERIES WITH STRAIGHT BASE AND ANTI-RELEASE LEVER

Some sizes of this series are also produced in stainless steel and are shown below in red.

Material:

Galvanized steel or **AISI 304 stainless steel**

Riveted pivots:

Galvanized steel or **AISI 304 stainless steel**

Supporting bushes:

Hardened and ground steel.

Handles:

Red polyurethane resistant to oils, grease and other chemical agents.

Performance:

Form BL and **form BLX** with open clamping lever and two flanged washers.

Form FL and **form FLX** with full clamping lever and bolt retainers to be welded in the desired position and angle.

Spindles:

To be ordered separately (see Accessories on page 87).

Features and applications:

The main feature of this series is the special anti-release lever with the purpose of avoiding any accidental openings caused by vibrations; and to block the tool in the open position; these tools are designed to prevent the operator's fingers from being crushed by the levers when opening. During the closing, the clamping lever is guided laterally to ensure greater stability against possible transverse stresses. A special grease is placed between two contacting surfaces during assembly.

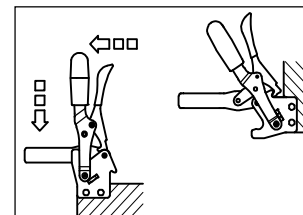

Code	Description	Stainless steel Code	Description	A	B	C	D	E	F	G	H	I	L	M	N	O	P	Q	Z	Fh (daN)	gr.
AA584	130/BL	AS202	130/BLX	85	156	35-36	50	25,5	35	10	12,5÷19		6,2	16	6,5÷7,5	28	M6	5,6	71	105	275
AA588	130/FL	AS206	130/FLX	86	156	35-36	51	25,5	35	10	12,5÷19	5		16	6,5÷7,5		M6	5,6		105	280
AA592	230/BL	AS212	230/BLX	110,5	183	41,5	67,5	30	43	12	18÷21		8,5	18	6,5	40	M8	6,7	94	200	380
AA596	230/FL	AS216	230/FLX	112	183	41,5	69	30	43	12	18÷21	6		18	6,5		M8	6,7		200	390

VERTICAL SERIES WITH ANTI-RELEASE LEVER AND EXTENDED CLAMPING LEVER

Material:

Galvanized steel

Riveted pivots:

Galvanized steel

Supporting bushes:

Hardened and ground steel

Handles:

Red polyurethane resistant to oils, grease and other chemical agents.

Performance:

Form ELS with extended clamping lever and folded base.

Form FLS with extended clamping lever and straight base.

Spindles:

To be ordered separately (see Accessories on page 87).

Extensions:

The models are supplied with AP6 and AP8 extension as per the drawing and with two flanged washers (see Accessories on page 90).

Features and applications:

The main features of this series are the special anti-release lever and the special extension of the locking arm to facilitate the specific use in control templates; these tools are designed to prevent the operator's fingers from being crushed by the levers when opening. During the closing, the clamping lever is guided laterally to ensure greater stability against possible transverse stresses.

A special grease is placed between two contacting surfaces during assembly.

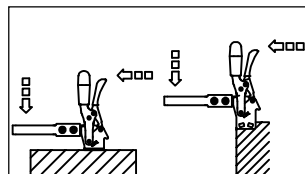

FORM ELS



PATENTED

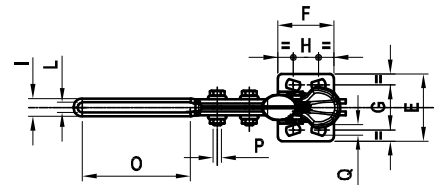
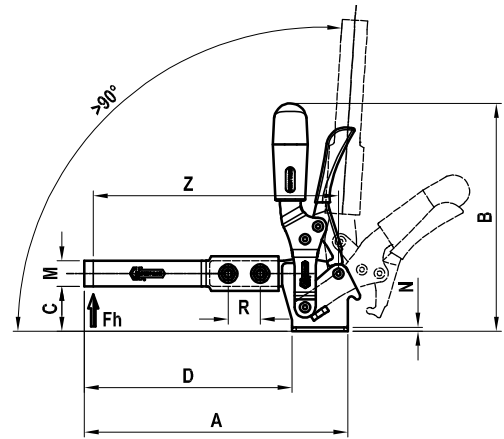

FORM FLS



PATENTED

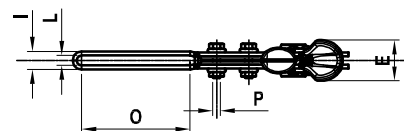
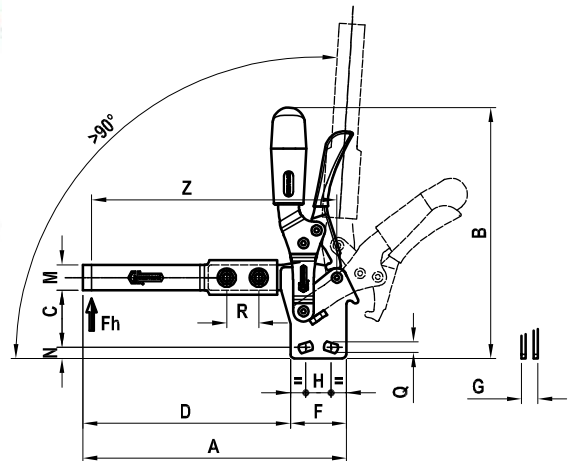

Code	Description	A	B	C	D	E	F	G	H	I	L	M	N	O	P	Q	R	Z	Fh daN	gr.
AA587	130/ELS	164	142	28	129	42	35	27÷29	12,5÷19	11,3	6,3	16	2,5	67,5	M6	5,6	20	152	50	375
AA589	130/FLS	164	156	35÷36	129	25,5	35	10	12,5÷19	11,3	6,3	16	6,5÷7,5	67,5	M6	5,6	20	152	50	375
AA595	230/ELS	198	168	33,5	155	45	43	32	19,5	14,2	8,2	18	3	71,5	M8	6,7	26	182	100	545
AA597	230/FLS	198	183	41,5	155	30	43	12	19,5	14,2	8,2	18	6,5	71,5	M8	6,7	26	182	100	545

FORM AV

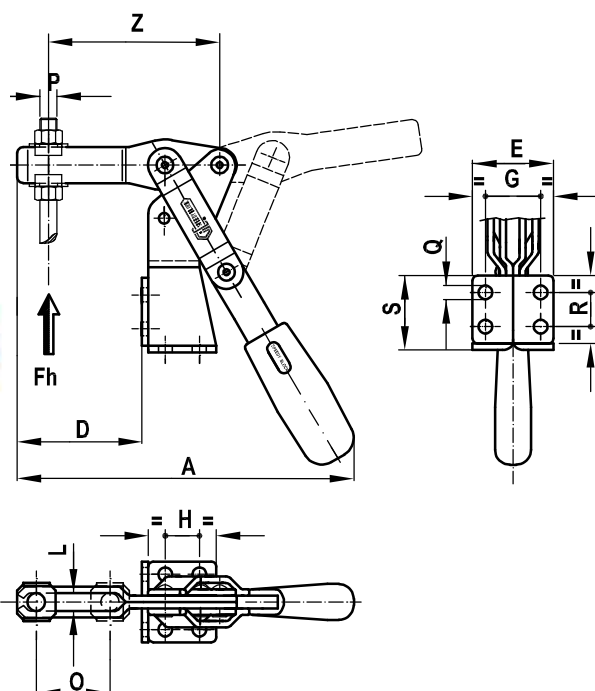

FORM EV

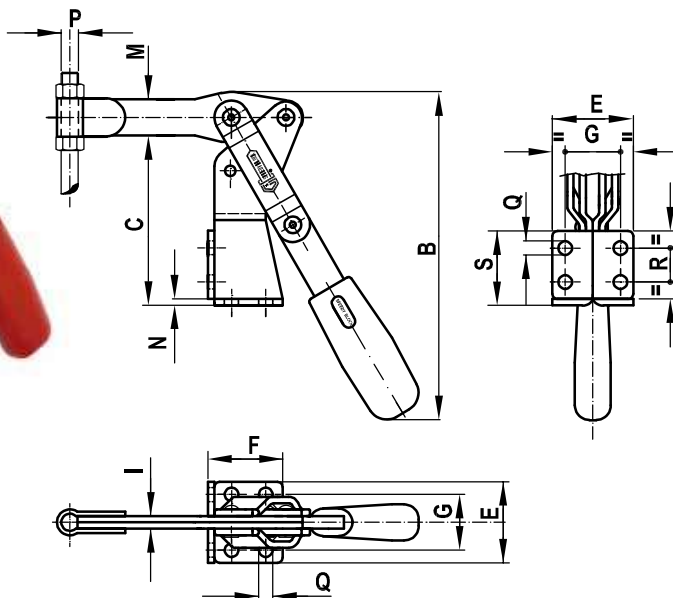

VERTICAL SERIES WITH FOLDED AND FRONT BASE

Material:

Galvanized steel

Riveted pivots:

Galvanized steel

Supporting bushes:

Hardened and ground steel

Handles:

Red polyurethane resistant to oils, grease and other chemical agents.

Performance:

Form AV with open clamping lever and two flanged washers.

Form EV with full clamping lever and bolt retainers to be welded in the desired position and angle.

Spindles:

To be ordered separately (see Accessories on page 87).

A special grease is placed between two contacting surfaces during assembly. This series is pneumatically actuated it is found on page 76-77.

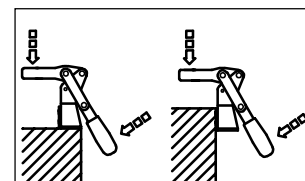

Code	Description	A	B	C	D	E	F	G	H	I	L	M	N	O	P	Q	R	S	Z	Fh (daN)	gr.
AA220	200/AV	157	154	76	58,5	38	35	26	16		8,5	17	3	34	M8	6,5	16	32	86	120	430
AA225	200/EV	159	154	76	60,5	38	35	26	16	6		17	3		M8	6,5	16	32		120	430
AA320	300/AV	193	198	108	76	48	48	30	28		10,4	20	3	42	M10	8,5	30	51	110	190	800
AA325	300/EV	195	198	108	78	48	48	30	28	8		20	3		M10	8,5	30	51		190	800

VERTICAL SERIES WITH STRAIGHT AND FRONT BASE

Material:

Galvanized steel

Riveted pivots:

Galvanized steel

Supporting bushes:

Hardened and ground steel

Handles:

Red polyurethane resistant to oils, grease and other chemical agents.

Performance:

Form AVF with open clamping lever and two flanged washers.

Form EVF with full clamping lever and bolt retainers to be welded in the desired position and angle.

Spindles:

To be ordered separately (see Accessories on page 87).

A special grease is placed between two contacting surfaces during assembly. This pneumatic actuated series is found on page 78-791.

FORM AVF

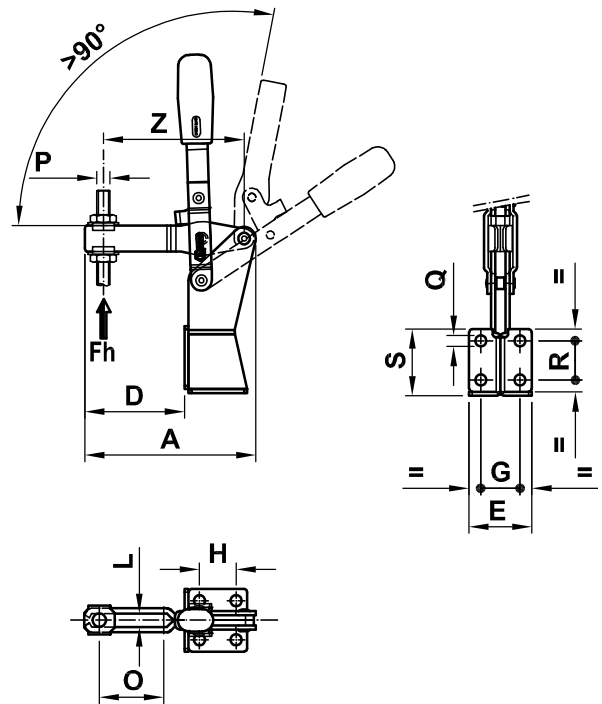

FORM EVF

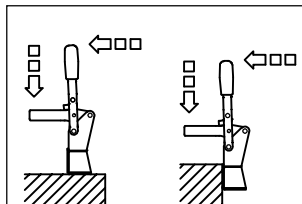
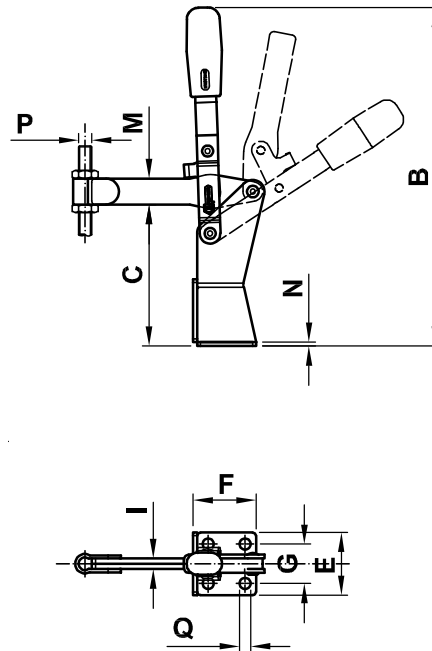

Code	Description	A	B	C	D	E	F	G	H	I	L	M	N	O	P	Q	R	S	Z	Fh (daN)	90°
AA221	200/AVF	103	203	77	59	38	35	26	16		8,5	17	3	36	M8	6,5	16	32	86	160	390
AA226	200/EVF	105	203	77	61	38	35	26	16	6		17	3		M8	6,5	16	32		160	400
AA321	300/AVF	130	258	108	76	48	48	30	28		10,3	20	3	50	M10	8,5	30	48	110	240	680
AA326	300/EVF	132	258	108	77,5	48	48	30	28	8		20	3		M10	8,5	30	48		240	690

FORM AVF

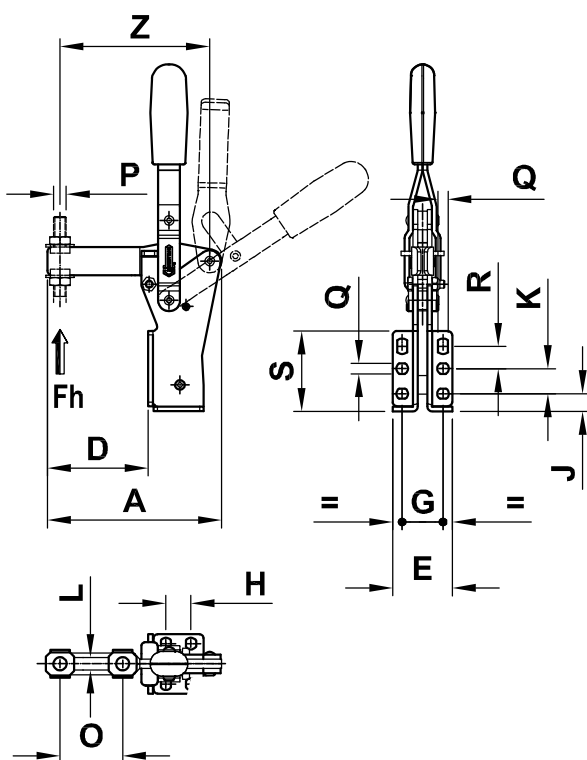

VERTICAL SERIES WITH STRAIGHT AND FRONT BASE

Material:

Galvanized steel

Riveted pivots:

Galvanized steel

Supporting bushes:

Hardened and ground steel

Handles:

Red polyurethane resistant to oils, grease and other chemical agents.

Performance:

Form AVF with open clamping lever and two flanged washers.

Form EVF with full clamping lever and bolt retainers to be welded in the desired position and angle.

Spindles:

To be ordered separately (see Accessories on page 87).

A special grease is placed between two contacting surfaces during assembly. This pneumatic actuated series is found on page 79.

FORM EVF

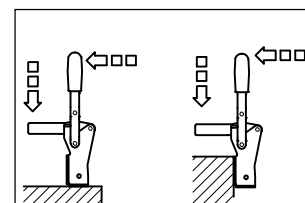
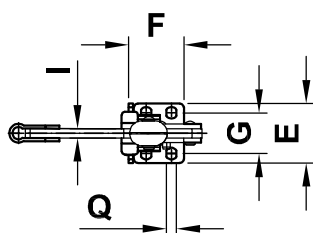
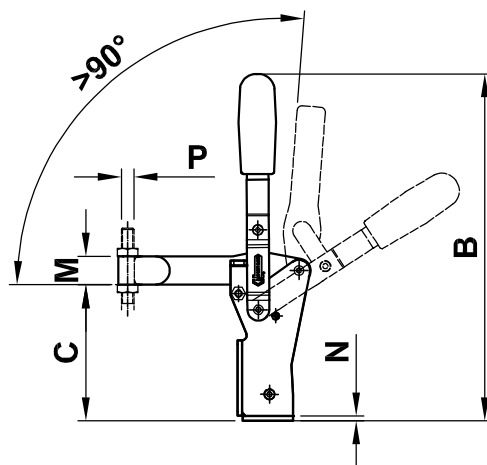
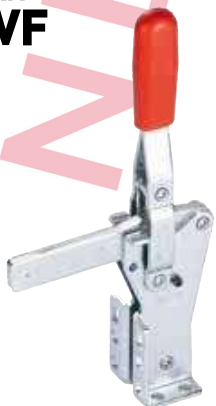

Code	Description	A	B	C	D	E	F	G	H	I	J	K	L	M	N	O	P	Q	R	S	Z	Fh (daN)	gf Δ
AA090	75/AVF	67	120	43	35,5	34	22	24	12,5		10	12,5	5,2	11	2	20	M5	4,5		30	56	75	130
AA092	75/EVF	67,5	120	43	36,5	34	22	24	12,5	4	10	12,5		11	2		M5	4,5		30		75	130
AA142	130/AVF	85	184	70	43	42	28	27	12,5		16	12,5	6,2	16	2,5	28	M6	5,6	12,5	49	71	110	300
AA144	130/EVF	86	184	70	44	42	28	27	12,5	5	16	12,5		16	2,5		M6	5,6	12,5	49		110	300
AA223	230/AVF	111	222	87	64	38	32	26	16		11	16	8,5	18	3	40	M8	6,5	14,25	51	94	220	500
AA228	230/EVF	112	222	87	65	38	32	26	16	6	11	16		18	3		M8	6,5	14,25	51		220	500
AA322	330/AVF	129	259	108	71	48	45	30	28		19	30	10,5	22	3,5	45	M10	8,5	20	79	110	260	800
AA328	330/EVF	131	259	108	73	48	45	30	28	7	19	30		22	3,5		M10	8,5	20	79		260	800

HEAVY-DUTY VERTICAL SERIES

Material:

Weldable phosphated steel.

Pivots:

Hardened and ground steel.

Supporting bushes:

Hardened and ground steel.

Handles:

Red polyurethane resistant to oils, grease and other chemical agents.

Features and applications:

Series generally used for heavy-duty applications requiring higher resistant forces. The clamps of this series are built to be easily disassembled for reworking of the individual elements depending on the requirements of use.

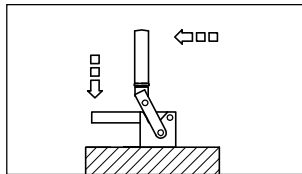

FORM F

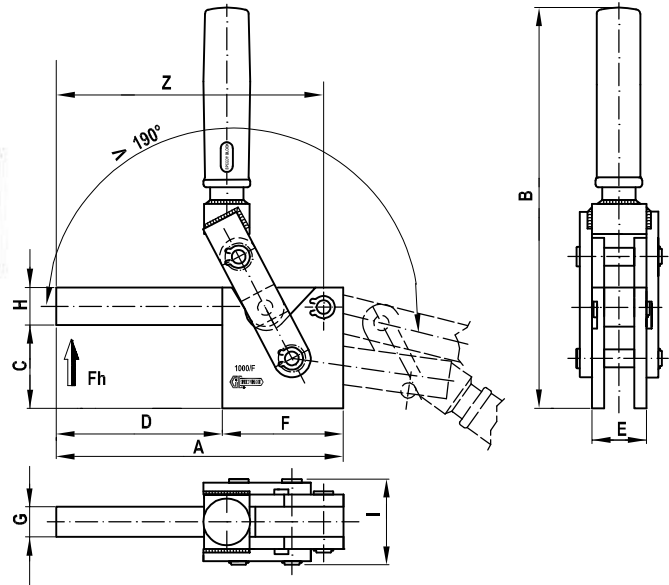

Code	Description	A	B	C	D	E	F	G	H	I	Z	Fh (daN)	gr.
AA900	1000/F	190	265	55	110	36	80	20	25	57,5	176	1000	2400
AA905	2000/F	220	295	65	120	36	100	20	35	57,5	200	2000	3600
AA910	3000/F	250	320	80	140	45	110	25	40	71	228	3000	5700

