



PNEUMATIC SERIES

This series combines the advantages of toggle action (even in case of pressure loss the tool remains closed) with the possibilities offered by the pneumatics:

- Constant FS clamping force independent of the operation.
- Possibility of actuating several devices at the same time.
- Possibility of actuating various points; remote control performed also by machines.
- Several versions are available with magnetic cylinders that enable positioning control without contacts, to obtain electric command impulses in certain clamping situations.

The pneumatic series also contains vertical and push rod series with Fs clamping forces between 50 and 240 daN and Fh retaining forces from 70 to 450 daN for the light series; and Fs from 87 daN to 430 daN with Fh from 220 to 2000 daN for the heavy-duty series. The use of a filter - reducer - lubricator group is essential for a long and smooth operation of the cylinder, while for a long duration of the mechanical components we recommend using suitable flow regulators and calibrating the speed of the motions desired, starting from a low speed and gradually increasing this speed. The cylinders of the heavy-duty series (1000-2000/EPM/EPVM) already mount these flow regulators on the heads and they can be adjusted using a screw on the side of the air supply. For all the other cylinders, a fixed pin is present in the back head to slow down the stroke during the opening phase. Operating pressure between 2-6 bar. Ambient temperature $-30^{\circ} + 80^{\circ}\text{C}$. The Fs forces indicated in the catalogue were measured at a pressure of 4 bar.

PERFORMANCE

LIGHT SERIES: Components in case-hardening sheet steel. Hardened and tempered supporting pivots. Supporting bushes (for sizes from 200 daN and over) undergo case-hardening and grinding.

HEAVY-DUTY SERIES: Base made of black varnished spheroidal cast iron. Other parts made of galvanized (weldable) steel. Supporting pivots undergo case hardening.

REINFORCED HEAVY-DUTY SERIES: Base body made of black phosphated steel sheet; cemented and ground support pins and bushes.

Double-acting cylinder with adjustable shock absorption. The tools of this series are built so as to be easily disassembled: the pivots are fixed axially with seeger rings.

LIGHT PNEUMATIC SERIES

Some sizes of this series are also produced for Magnetic performance and are shown in the table below ("magnetic version")

Material: Sheet metal and galvanized steel riveted pivots. Hardened and ground steel rotation pivots.

Performance:

Form AP3 with open clamping lever and two flanged washers.

Form EP3 with full clamping lever and bolt retainers.

Form APM just like AP3 but with magnetic cylinder for the detection of the position.

Form EPM just like EP3 but with magnetic cylinder for the detection of the position.

Cylinder:

Maximum operating pressure 6 bar.

Maximum operating temperature 80°C

The AU460 model reed switch is used for detecting the position, for sizes 200 and 300; model AU450 is used for size 400 (see Accessories on page 87).

The proximity switches must be ordered separately.

Spindles: To be ordered separately (see Accessories on page 87).

Features and applications:

We recommend using a filter-reducer-lubricator group for a long and smooth operation of the cylinder, while for a long duration of the mechanical components we recommend using suitable flow regulators and calibrating the speed of the motions desired, starting from a low speed and gradually increasing this speed.

A special grease is placed between two contacting surfaces during assembly.

This manually actuated series is found on page 10.

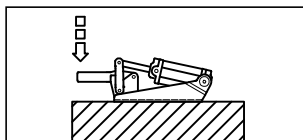

FORM AP3

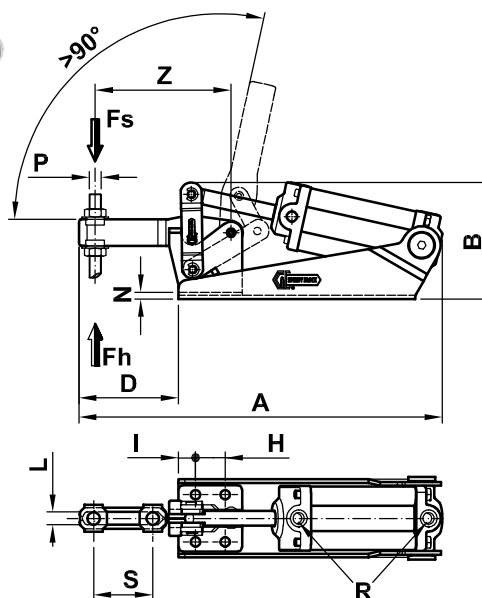

FORM EP3

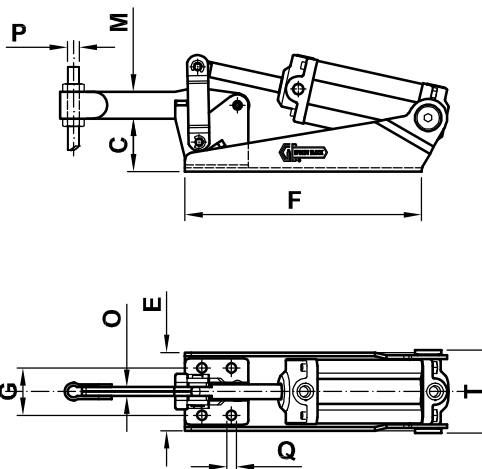

Code	Description	Magnetic Version Code	Description	A	B	C	D	E	F	G	H	I	L	M	N	O	P	Q	R	S	T	Z	Fh (daN)	Fs (daN)	gr.
A0020	70/AP3			163	51,5	21	38	42	92	24	15	6,5±7	5,2	11	4		M5	4,5	1/8"	20	45	56	70	50	500
A0025	70/EP3			163	51,5	21	39	42	92	24	15	6,5±7		11	4	4	M5	4,5	1/8"		45		70	50	500
A0041	125/AP3			200	70,5	30	50	47,5	150	29	19	8±11,2	6,2	14	4,5		M6	5,5	1/8"	23	46	71	160	70	700
A0046	125/EP3			201	70,5	30	51	47,5	150	29	19	8±11,2		14	4,5	5	M6	5,5	1/8"		46		160	70	700
A0161	200/AP3	A0162	200/APM	246	79	36	67,5	53	160	32	20	11,5±12	8,5	18	5,5		M8	6,5	1/8"	40	56	94	220	90	1070
A0166	200/EP3	A0167	200/EPM	248	79	36	69,5	53	160	32	20	11,5±12		18	5,5	6	M8	6,5	1/8"		56		220	90	1070
A0201	300/AP3	A0202	300/APM	304,5	98	48	78,5	74	195,5	46	29	8,5±10,5	10,5	20	8,5		M10	8,5	1/4"	42	66	110	270	120	2100
A0206	300/EP3	A0207	300/EPM	306	98	48	80	74	195,5	46	29	8,5±10,5		20	8,5	8	M10	8,5	1/4"		66		270	120	2100
A0301	400/AP3	A0302	400/APM	360	107,5	51	110	74	216	45	32	10	12,5	22	10		M12	8,5	1/4"	66	80	143	300	140	3100
A0306	400/EP3	A0307	400/EPM	362	107,5	51	112	74	216	45	32	10		22	10	10	M12	8,5	1/4"		80		300	140	3100

FORM AP

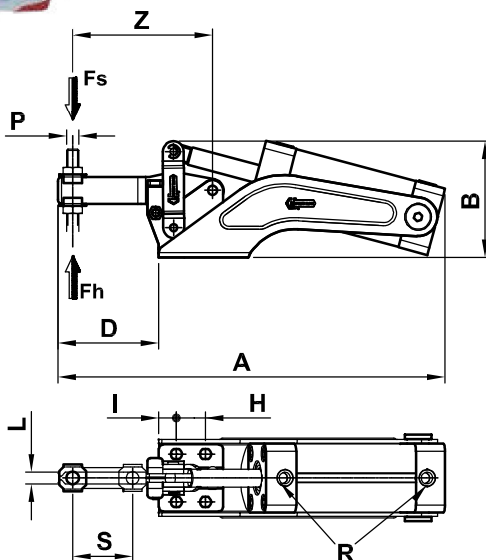

FORM EP

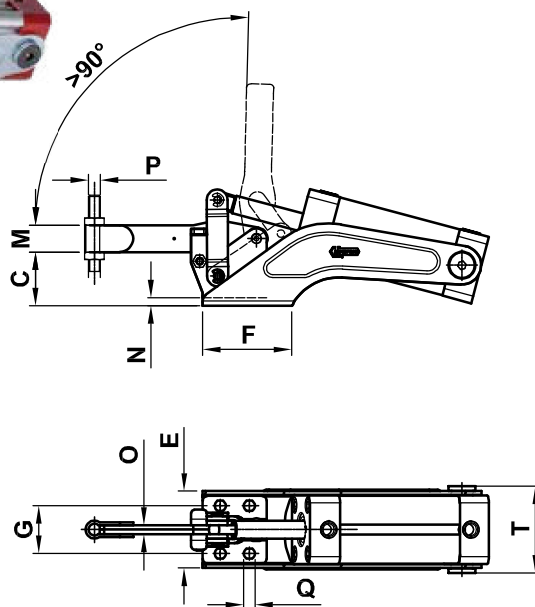

LIGHT PNEUMATIC SERIES

This series has been completely redesigned, giving the items a greater operating life.

Material:

Sheet metal and galvanized steel riveted pivots.

Hardened and ground steel rotation pivots, running into sockets with similar feature.

Pneumatic cylinder:

All the cylinders of this series are magnetic, with a pneumatic brake inside the back head.

Maximum operating pressure 6 bar.

Maximum operating temperature 70°C.

The electronic switch for detecting the position is AU570 (see the presentation at page 87) and must be ordered separately.

Spindle:

To be ordered separately (see accessories on page 87).

Feature and applications:

A filter-reducer-lubricator group is recommended for a long and smooth operation of the cylinder, while for a long duration of the mechanical components we recommend using suitable flow regulations and calibrating the speed of the motion desired.

You can find the instructions for the set-up and daily use of the items of this series on the technical sheets reported on our website.

The values of the clamping force F_s on the chart are measured at 6 bar pressure air. This pneumatically operated series can be found on p. 10.

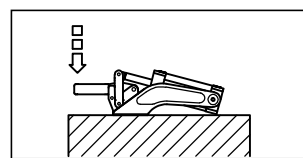

Code	Description	A	B	C	D	E	F	G	H	I	L	M	N	O	P	Q	R	S	T	Z	Fh (daN)	Fs (daN)	gr.
AO400	75/AP	162	54	22	38	40	40	24	14,5±16,5	6,5±7	5,2	11	3,5	M5	4,5	M5	20	47	56	70	38	400	
AO402	75/EP	163	54	22	39	40	40	24	14,5±16,5	6,5±7	11	3,5	4	M5	4,5	M5	47	70	38	400			
AO408	130/AP	195	66	30	50	47,5	45	27±29	12,5±19	8±11,2	6,2	16	4,5	M6	5,6	1/8"	28	51	71	160	80	650	
AO410	130/EP	196	66	30	51	47,5	45	27±29	12,5±19	8±11,2	16	4,5	5	M6	5,6	1/8"	51	160	80	650			
AO416	230/AP	259	78	36	67	51	55	32	18,5±20,5	11,5±12	8,5	18	5,5	M8	6,7	1/8"	40	58	94	220	120	1150	
AO418	230/EP	261	78	36	69	51	55	32	18,5±20,5	11,5±12	18	5,5	6	M8	6,7	1/8"	58	220	120	1130			
AO428	330/AP	307	96	46	78	74	55	45±46	29±32	8,5±10,5	10,5	22	6,5	M10	8,6	1/4"	45	70	110	250	175	1850	
AO430	330/EP	309	96	46	80	74	55	45±46	29±32	8,5±10,5	22	6,5	7	M10	8,6	1/4"	70	250	175	1900			
AO440	430/AP	363	114	55	88	73	70	45	32	14	12,5	26	7,5	M12	8,5	1/4"	48	82,5	124	290	225	3300	
AO442	430/EP	364	114	55	90	73	70	45	32	14	26	7,5	10	M12	8,5	1/4"	82,5	290	225	3300			

LIGHT PNEUMATIC SERIES

The sizes of this series are also produced for Magnetic performance and are shown in the table (see "magnetic version").

Material: Sheet metal and galvanized steel riveted pivots.

Hardened and ground steel rotation pivots.

Performance:

Form APV3 with open clamping lever and two flanged washers.

Form EPV3 with full clamping lever and bolt retainers.

Form APVM just like APV3 but with magnetic cylinder for the detection of the position.

Form EPVM just like EPV3 but with magnetic cylinder for the detection of the position.

Cylinder: Maximum operating pressure 6 bar.

Maximum operating temperature 80°C

Model AU460 is the reed switch for detecting the position

(see Accessories on page 87).

The proximity switches must be ordered separately.

Spindles:

To be ordered separately

(see Accessories on page 87).

Features and applications:

We recommend using a filter-reducer-lubricator group for a long and smooth operation of the cylinder, while for a long duration of the mechanical components we recommend using suitable flow regulators and calibrating the speed of the motions desired, starting from a low speed and gradually increasing this speed.

A special grease is placed between two contacting surfaces during assembly.

This manually actuated series is found on page 15.

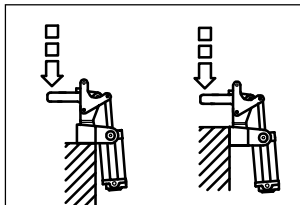

FORM APV3

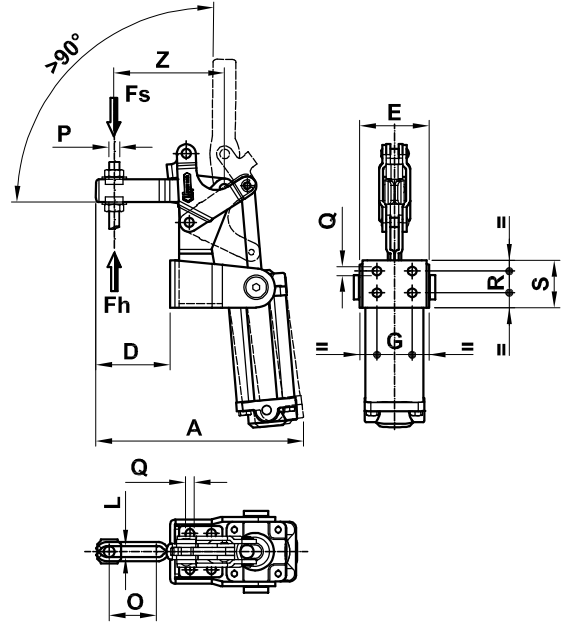

FORM EPV3

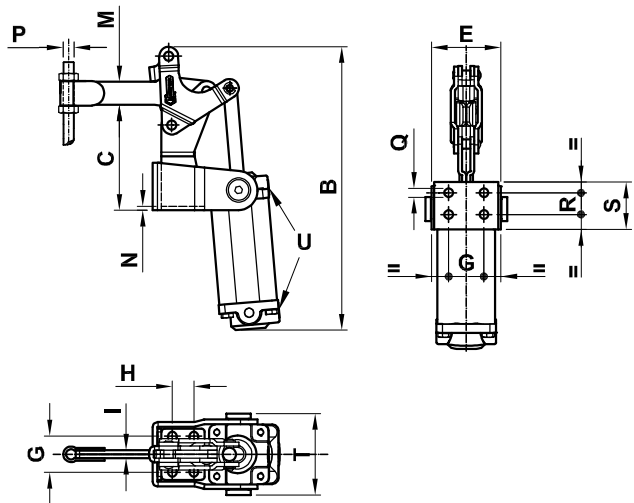

Code	Description	Magnetic Version Code	Description	A	B	C	D	E	G	H	I	L	M	N	O	P	Q	R	S	T	U	Z	Fh (daN)	Fs (daN)	gr.
A0181	200/APV3	A0182	200/APVM	149	210	77	55	51	26	16		8,5	17	3	34	M8	6,5	16	35	59,5	1/8"	88	160	90	1200
A0186	200/EPV3	A0187	200/EPVM	151	210	77	57	51	26	16	6		17	3		M8	6,5	16	35	59,5	1/8"	88	160	90	1200
A0221	300/APV3	A0222	300/APVM	186	258	108	71	60,5	30	28		10	20	3	42	M10	8,5	30	50	68,5	1/4"	110	240	120	2450
A0226	300/EPV3	A0227	300/EPVM	187,5	258	108	72,5	60,5	30	28	8		20	3		M10	8,5	30	50	68,5	1/4"	110	240	120	2450

FORM APV

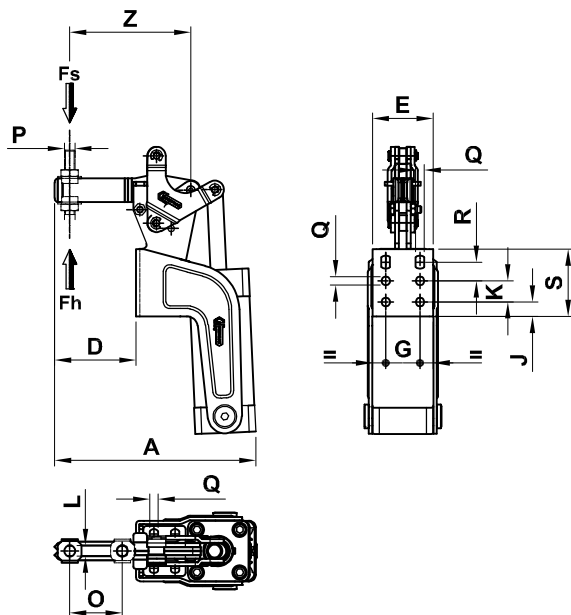

FORM EPV

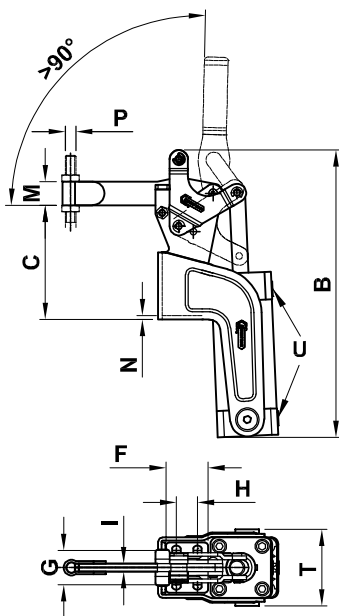

LIGHT PNEUMATIC SERIES

This series has been completely redesigned, giving the items a greater operating life.

Material:

Sheet metal and galvanized steel riveted pivots.
Hardened and ground steel rotation pivots, running into sockets with similar feature.

Pneumatic cylinder:

All the cylinders of this series are magnetic, with a pneumatic brake inside the back head.
Maximum operating pressure 6 bar.
Maximum operating temperature 70°C.
The electronic switch for detecting the position is AU570 (see the presentation at page 87) and must be ordered separately.

Spindle:

To be ordered separately (see accessories on page 87)

Feature and applications:

A filter-reducer-lubricator group is recommended for a long and smooth operation of the cylinder, while for a long duration of the mechanical components we recommend using suitable flow regulations and calibrating the speed of the motion desired.

You can find the instructions for the set-up and daily use of the items of this series on the technical sheets reported on our website.

The values of the clamping force F_s on the chart are measured at 6 bar pressure air. This pneumatically operated series can be found on p. 10.

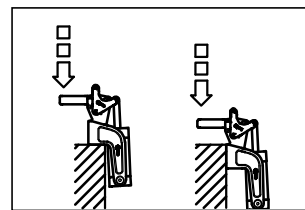

Code	Description	A	B	C	D	E	F	G	H	I	J	K	L	M	N	O	P	Q	R	S	T	U	Z	Fh (daN)	Fs (daN)	gr.
AO404	75/APV	99	151	43	34	40	22	24	12,5	10	12,5	5,2	11	2	21	M5	4,5	30	47	M5	56,5	75	57	500		
AO406	75/EPV	99	151	43	35	40	22	24	12,5	4	10	12,5	11	2	21	M5	4,5	30	47	M5	75	57	500			
AO412	130/APV	118	167	70	41	47	28	27	12,5	16	12,5	6,2	16	2,5	28,5	M6	5,6	12,5	49	51	1/8"	72	110	61	750	
AO414	130/EPV	119	167	70	42	47	28	27	12,5	5	16	12,5	16	2,5	28,5	M6	5,6	12,5	49	51	1/8"	72	110	61	750	
AO420	230/APV	153	218	87	62	46	32	26	16	11	16	8,5	18	3	41	M8	6,5	14,25	51	58	1/8"	94,5	220	126	1250	
AO422	230/EPV	155	218	87	63	46	32	26	16	6	11	16	18	3	41	M8	6,5	14,25	51	58	1/8"	94,5	220	126	1255	
AO432	330/APV	182	263	108	68	56	45	30	28	19	30	10,5	22	3,5	45	M10	8,5	20	79	70	1/4"	110	260	180	2200	
AO434	330/EPV	184	263	108	70	56	45	30	28	7	19	30	22	3,5	45	M10	8,5	20	79	70	1/4"	110	260	180	2200	

LIGHT PNEUMATIC SERIES

The sizes of this series are also produced for Magnetic performance and are shown in the table (see "magnetic version")

Material:

Sheet metal and galvanized steel riveted pivots.
Hardened and ground steel rotation pivots.

Performance:

Form APV3S with open clamping lever and two flanged washers.

Form EPV3S with full clamping lever and bolt retainers.

Form APVMS just like APV3S but with magnetic cylinder for the detection of the position.

Form EPVMS just like EPV3S but with magnetic cylinder for the detection of the position.

Cylinder:

Maximum operating pressure 6 bar.
Maximum operating temperature 80°C
Model AU460 is the reed switch for detecting the position (see Accessories on page 87).

The proximity switches must be ordered separately.

Handles:

Red polyurethane resistant to oils, grease and other chemical agents.

Spindles:

To be ordered separately (see Accessories on page 87).

Features and applications:

The tools of this series are used when there is a need for pneumatic closing (generally simultaneous closing of the tools remotely) but manual and single opening is mandatory. We recommend using a filter-reducer-lubricator group for a long and smooth operation of the cylinder, while for a long duration of the mechanical components we recommend using suitable flow regulators and calibrating the speed of the motions desired, starting from a low speed and gradually increasing this speed.

A special grease is placed between two contacting surfaces during assembly. This manually actuated series is found on page 16.

FORM APV3S

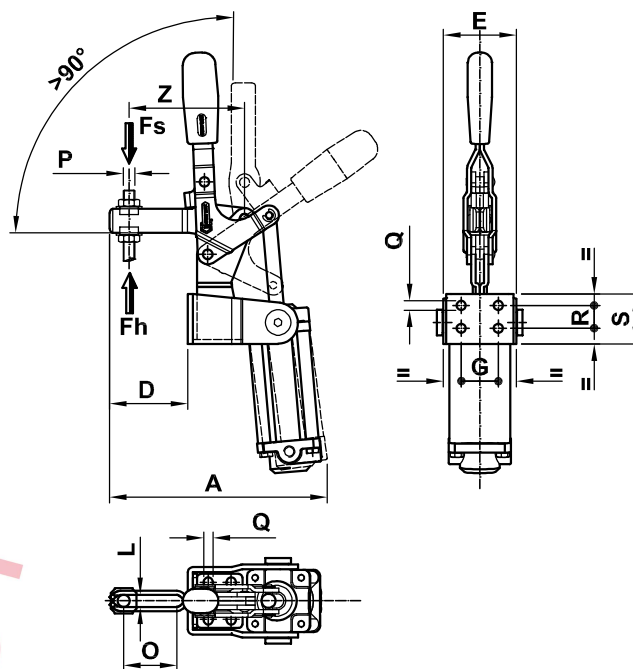

FORM EPV3S

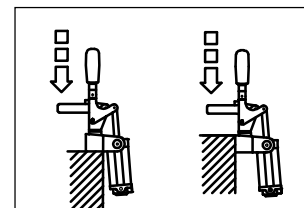
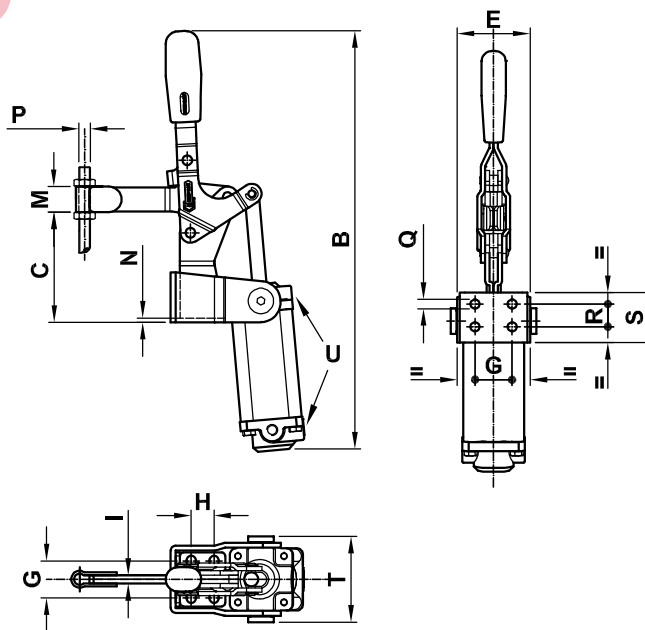

Code	Description	Magnetic Version Code	Description	A	B	C	D	E	G	H	I	L	M	N	O	P	Q	R	S	T	U	Z	Fh (daN)	Fs (daN)	gr.
A0184	200/APV3S	A0185	200/APVMS	149	296	77	55	51	26	16		8,5	17	3	34	M8	6,5	16	35	59,5	1/8"	88	160	90	1200
A0189	200/EPV3S	A0190	200/EPVMS	151	296	77	57	51	26	16	6		17	3		M8	6,5	16	35	59,5	1/8"		160	90	1200
A0224	300/APV3S	A0225	300/APVMS	186	360	108	71	60,5	30	28		10	20	3	42	M10	8,5	30	50	68,5	1/4"	110	240	120	2450
A0229	300/EPV3S	A0230	300/EPVMS	187,5	360	108	72,5	60,5	30	28	8		20	3		M10	8,5	30	50	68,5	1/4"		240	120	2450

FORM APVS

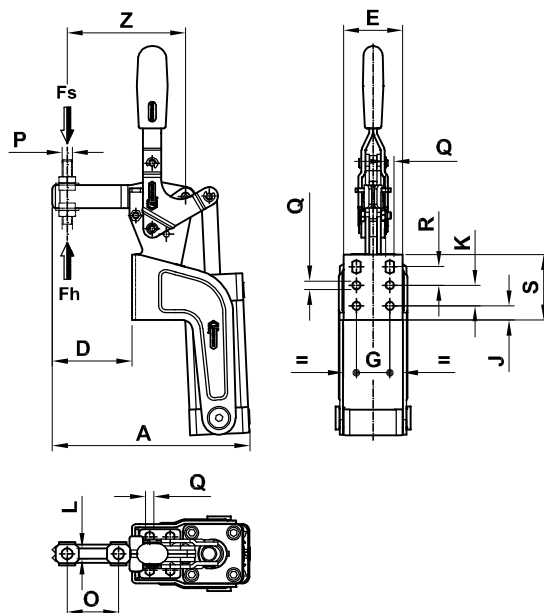

FORM EPVS

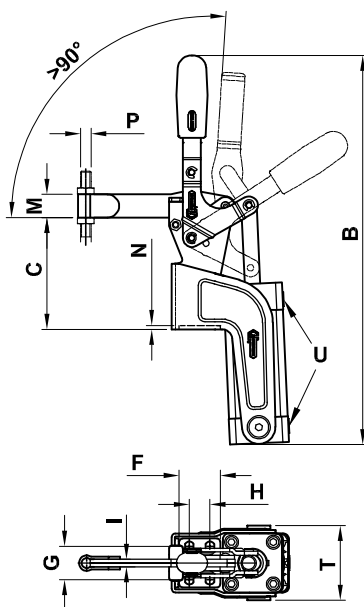

LIGHT PNEUMATIC SERIES

This series has been completely redesigned, giving the items a greater operating life.

Material:

Sheet metal and galvanized steel riveted pivots. Hardened and ground steel rotation pivots, running into sockets with similar feature.

Pneumatic cylinder:

All the cylinders of this series are magnetic, with a pneumatic brake inside the back head.

Maximum operating pressure 6 bar. Maximum operating temperature 70°C. The electronic switch for detecting the position is AU570 (see the presentation at page 87) and must be ordered separately.

Handle:

Red polyurethan resistant to oils, grease and other chemical agents.

Spindle:

To be ordered separately (see accessories on page 87)

Feature and applications:

A filter-reducer-lubricator group is recommended for a long and smooth operation of the cylinder, while for a long duration of the mechanical components we recommend using suitable flow regulations and calibrating the speed of the motion desired.

You can find the instructions for the set-up and daily use of the items of this series on the technical sheets reported on our website.

The values of the clamping force F_s on the chart are measured at 6 bar pressure air. This pneumatically operated series can be found on p. 16/17.

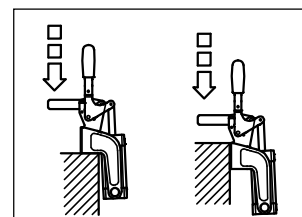

Code	Description	A	B	C	D	E	F	G	H	I	J	K	L	M	N	O	P	Q	R	S	T	U	Z	Fh (daN)	Fs (daN)	gr.
AD424	230/APVS	153	302	87	62	46	32	26	16		11	16	8,5	18	3	41	M8	6,5	14,25	51	58	1/8"	94,5	220	126	1350
AD426	230/EPVS	155	302	87	63	46	32	26	16	6	11	16		18	3		M8	6,5	14,25	51	58	1/8"		220	126	1400
AD436	330/APVS	182	363	108	68	56	45	30	28		19	30	10,5	22	3,5	45	M10	8,5	20	79	70	1/4"	110	260	180	2300
AD438	330/EPVS	184	363	108	70	56	45	30	28	7	19	30		22	3,5		M10	8,5	20	79	70	1/4"		260	180	2300

HEAVY-DUTY PNEUMATIC SERIES

Material:

Base made of black varnished spheroidal cast iron;
Lever in galvanized steel;
Hardened and ground pivots.

Cylinder:

ISO Magnetic Standards.
Maximum operating pressure 10 bar.
Maximum operating temperature 80°C
Model AU470 is the reed switch for detecting the position to be ordered separately.

Features and applications:

These tools are designed to withstand high loads and a high number of operations.

We recommend using a filter-reducer-lubricator group for a long and smooth operation of the cylinder, while for a long duration of the mechanical components we recommend using the flow regulators found on the head for calibrating the speed of the motions desired, starting from a low speed and gradually increasing this speed.

A special grease is placed between two contacting surfaces during assembly.

FORM EPM

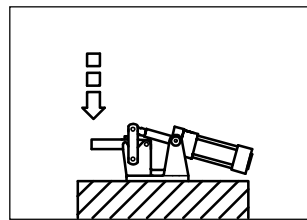
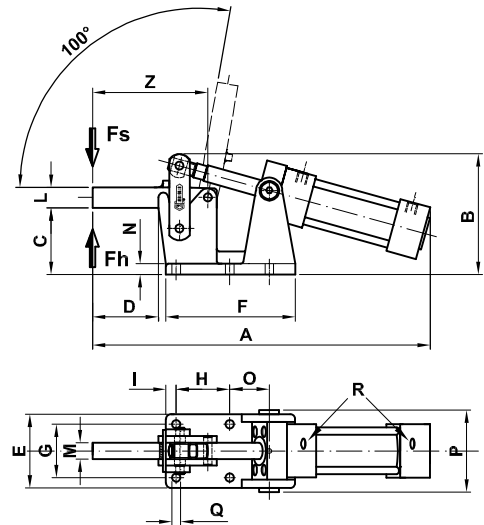

Code	Description	A	B	C	D	E	F	G	H	I	L	M	N	O	P	Q	R	Z	Fh (daN)	Fs (daN)	g _r
A0600	1000/EPM	410	146,5	80	80	90	155	65	65	12,5	25	20	13	48	102	10,5	1/4"	140	1000	320	6500
A0620	2000/EPM	487	171,5	90	100	100	176	70	70	15	35	20	13	56	112	10,5	3/8"	172	2000	380	9500

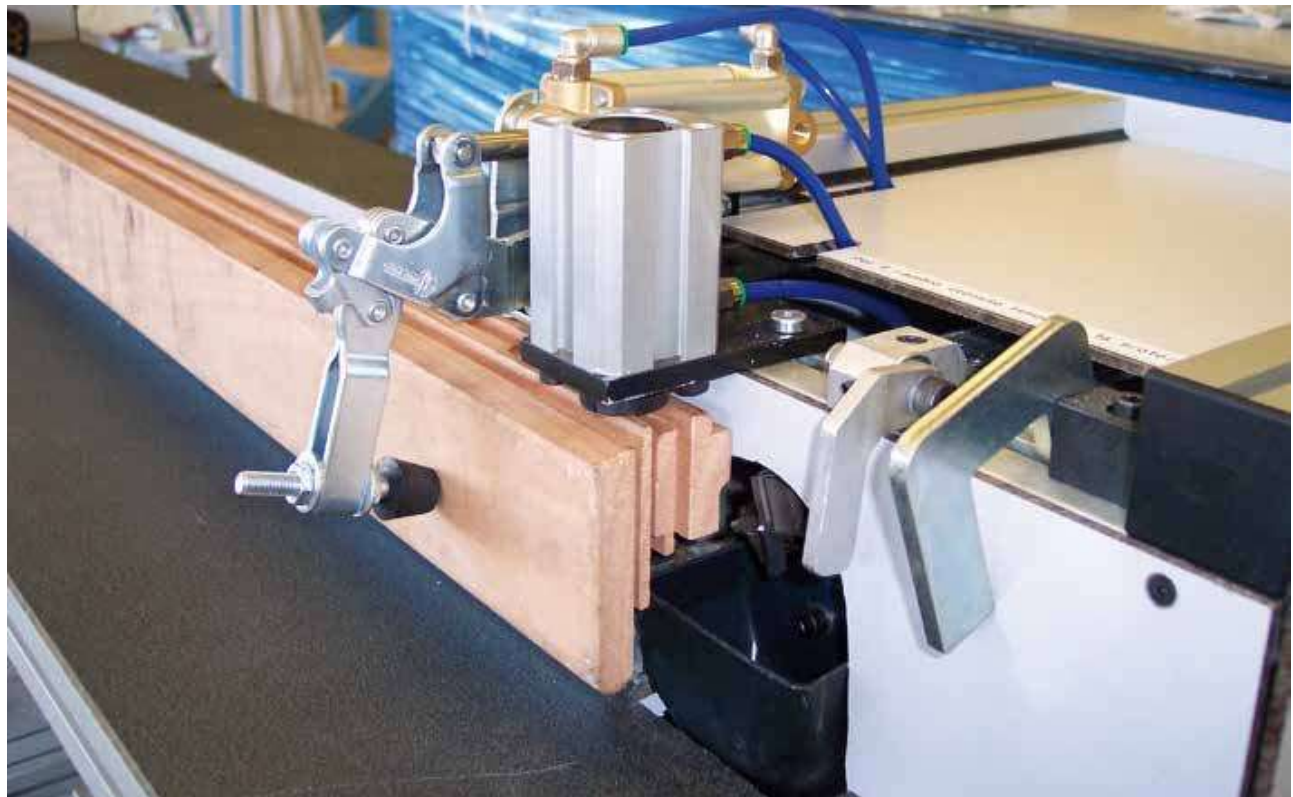

FORM EPVM

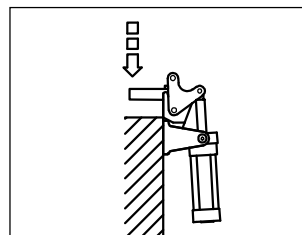
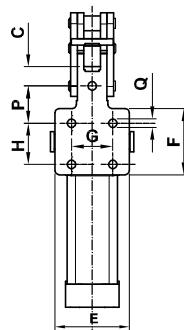
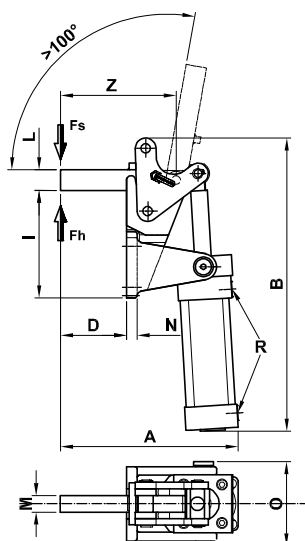

HEAVY-DUTY PNEUMATIC SERIES

Material:

Base made of black/varnished spheroidal cast iron.
Lever in galvanized steel;
Hardened and ground pivots.

Cylinder:

ISO Magnetic Standards
Maximum operating pressure 10 bar.
Maximum operating temperature 80°C
Model AU470 is the reed switch for detecting the position to be ordered separately.

Features and applications:

These tools are designed to withstand high loads and a high number of operations.

We recommend using a filter-reducer-lubricator group for a long and smooth operation of the cylinder, while for a long duration of the mechanical components we recommend using the flow regulators found on the head for calibrating the speed of the motions desired, starting from a low speed and gradually increasing this speed.

A special grease is placed between two contacting surfaces during assembly.

Code	Description	A	B	C	D	E	F	G	H	I	L	M	N	O	P	Q	R	Z	Fh (daN)	Fs (daN)	gf.
A0605	1000/EPVM	215	355		80	90	80	50	50	130	25	20	13	102		10,5	1/4"	140	1000	340	6500
A0625	2000/EPVM	246,5	424	45	100	100	90	54	58	157	35	20	14	112	45	12,5	3/8"	172	2000	432	9000



REINFORCED PNEUMATIC SERIES



REINFORCED HEAVY-DUTY PNEUMATIC SERIES

Material:

Phosphated Steel.

Pivots:

Hardened and ground Steel.

Supporting bushes:

Hardened and ground Steel.

Spindles:

To be ordered separately (see Accessories on page 87).

Features and applications:

the clamping levers are obtained by hot moulding; the series is generally used in clamping jobs with medium and heavy loads, on welding masks, carpentry works, moulds and where large clamping forces and strong repetitiveness of movements are required.

FORM LPV

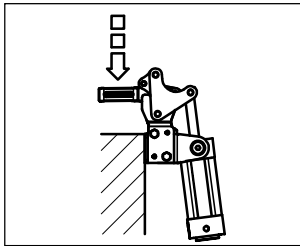
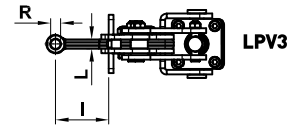
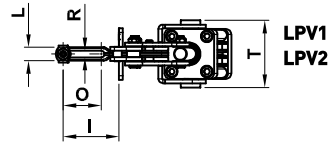
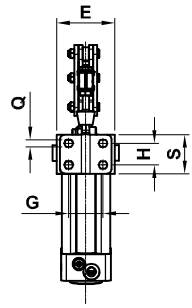
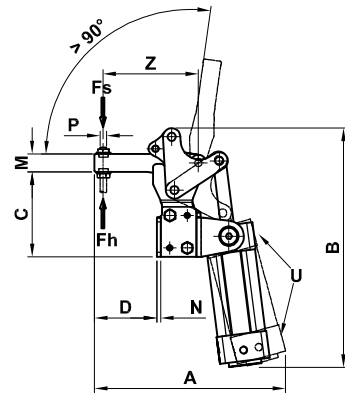

Code	Description	A	B	C	D	E	G	H	I	L	M	N	O	P	Q	R	S	T	U	Z	Fh (daN)	Fs (daN)	gr.
A0384	LPV1	172	215	77	57	54	32	20	51	12,3	16,6	3,5	35	M6	6,5	6,3	36	63	1/8"	89	220	87	1150
A0386	LPV2	195	288	106	71	65	44,5	30	60	20	24	5	35	M10	8,5	10,3	54	75	1/4"	115	440	122	2750
A0388	LPV3	239	372	141	80	78	54	55	68	12	31	6		M12	10,5	12,5	75	89	1/4"	139	850	228	5300





PUSH HEAVY-DUTY PNEUMATIC SERIES

Some sizes of this series are also produced for Magnetic performance and are shown in the table below (see "magnetic version").

Material:

Galvanized steel

Riveted pivots, push bar and control lever:

Galvanized steel

Basic clamp body:

Black varnished brass for size 70; hot forged steel and painted black for the other sizes.

Performance:

Form SP3 Tool equipped with normal pneumatic cylinder.

Form SPM Tool equipped with magnetic pneumatic cylinder.

Cylinder:

Maximum operating pressure 6 bar.

Maximum operating temperature 80°C.

The AU460 model reed switch is used for detecting the position, for sizes 360 and 1100; model AU450 is used for size 2100 (see Accessories on page 87).

The proximity switches must be ordered separately.

Spindles:

To be ordered separately (see Accessories on page 87).

Features and applications:

We recommend using a filter-reducer-lubricator group for a long and smooth operation of the cylinder, while for a long duration of the mechanical components we recommend using suitable flow regulators and calibrating the speed of the motions desired, starting from a low speed and gradually increasing this speed.

A special grease is placed between two contacting surfaces during assembly. This manually actuated series is found on page 41.

FORM SP3

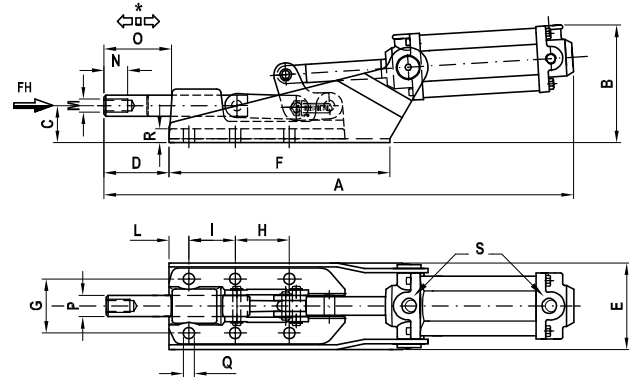

SELLING OUT

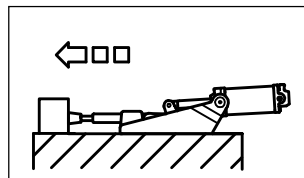

Code	Description	Magnetic Version Code	Description	A	B	C	D	E	F	G	H	I	L	M	N	O	P	Q	R	S	*	Fh (daN)	Fs (daN)	gf.
A0350	70/SP3			171	51	14	20	42	64	26	26		13	M6	12	22	8,5	4,3	8	1/8"	12	120	50	550
A0361	360/SP3	A0362	360/SPM	260	72,5	27,5	32	55	116	33,5	36,5		30	M8	15	34	12	5,5	9,5	1/8"	22	560	310	1300
A0371	1100/SP3	A0372	1100/SPM	355	89	28	49	66	167	41	41	35	15	M10	18	50	16	8,5	12	1/4"	32	1600	410	2400
A0381	2100/SP3	A0382	2100/SPM	468,5	100	38,5	61,5	81	231	50	50	50	35	M12	22	63,5	20	8,5	13	1/4"	45	2500	607	5000

FORM SP4



NEW

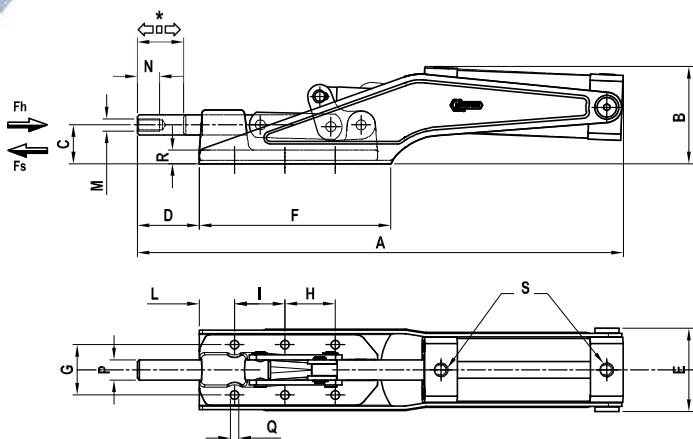

LIGHT PNEUMATIC SERIES

This series has been completely redesigned, giving the items a greater operating life.

Material:

Sheet metal and galvanized steel riveted pivots. Hardened and ground steel rotation pivots, running into sockets with similar feature.

Pneumatic cylinder:

All the cylinders of this series are magnetic, with a pneumatic brake inside the back head. Maximum operating pressure 6 bar. Maximum operating temperature 70°C. The electronic switch for detecting the position is AU570 (see the presentation at page 87) and must be ordered separately.

Spindle:

To be ordered separately (see accessories on page 87)

Feature and applications:

A filter-reducer-lubricator group is recommended for a long and smooth operation of the cylinder, while for a long duration of the mechanical components we recommend using suitable flow regulations and calibrating the speed of the motion desired.

You can find the instructions for the set-up and daily use of the items of this series on the technical sheets reported on our website.

The values of the clamping force F_s on the chart are measured at 6 bar pressure air. This pneumatically operated series can be found on p. 41.

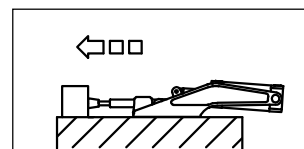

Code	Description	A	B	C	D	E	F	G	H	I	L	M	N	P	Q	R	S	*	Fh (daN)	Fs (daN)	gr.
A0444	70/SP4	163	50	13,5	20	48	70	26		26	13	M6	12	8,5	4,3	7,5	M5	12	120	78	500
A0446	360/SP4	274	69	27,5	32	58	94	33,5		36,5	30	M8	15	12	5,5	9,5	1/8"	23	560	129	1400
A0448	1100/SP4	361	85	28	49	70	138	41	41	35	15	M10	18	16	8,5	11	1/4"	32	1600	448	2600
A0450	2100/SP4	482	96,5	38,5	61,5	82,5	190	50	50	50	35	m12	22	20	8,5	13,5	1/4"	45	2500	552	5200